



National
Qualifications
2014

X713/75/02

**Chemistry
Section 1—Questions**

MONDAY, 12 MAY

9:00 AM—11:00 AM

Necessary data will be found in the Chemistry Data Booklet for National 5.

Instructions for the completion of Section 1 are given on Page two of your question and answer booklet X713/75/01.

Record your answers on the answer grid on Page three of your question and answer booklet

Before leaving the examination room you must give your question and answer booklet to the Invigilator; if you do not, you may lose all the marks for this paper.



* X 7 1 3 7 5 0 2 *

SECTION 1

1. In a reaction, 60 cm^3 of hydrogen gas was collected in 20 s.

What is the average rate of reaction, in $\text{cm}^3 \text{ s}^{-1}$, over this time?

A $\frac{60}{20}$

B $\frac{20}{60}$

C $\frac{1}{60}$

D $\frac{1}{20}$

2. Molecules in which four different atoms are attached to a carbon atom are said to be chiral.

Which of the following molecules is chiral?

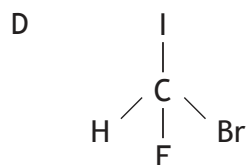
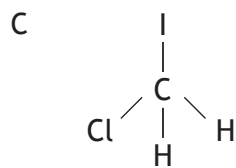
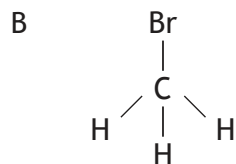
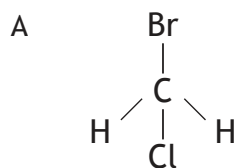

3. What is the charge on the zinc ion in the compound zinc phosphate $Zn_3(PO_4)_2$?

- A 2+
- B 3+
- C 2-
- D 3-

4. $Fe_2O_3 + x CO \longrightarrow y Fe + 3CO_2$

This equation will be balanced when

- A $x = 1$ and $y = 2$
- B $x = 2$ and $y = 2$
- C $x = 3$ and $y = 2$
- D $x = 2$ and $y = 3$.

5. An acidic solution contains

- A only hydrogen ions
- B only hydroxide ions
- C more hydrogen ions than hydroxide ions
- D more hydroxide ions than hydrogen ions.

6. Which of the following oxides, when shaken with water, would give an alkaline solution?

- A Calcium oxide
- B Nickel oxide
- C Nitrogen dioxide
- D Sulfur dioxide

7. Which of the following compounds is **not** a salt?

- A Calcium nitrate
- B Sodium chloride
- C Potassium sulfate
- D Magnesium hydroxide

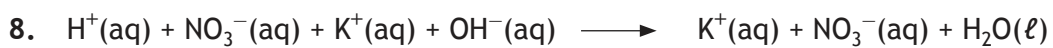

The spectator ions present in the reaction above are

- A $\text{K}^+(\text{aq})$ and $\text{NO}_3^-(\text{aq})$
- B $\text{K}^+(\text{aq})$ and $\text{H}^+(\text{aq})$
- C $\text{OH}^-(\text{aq})$ and $\text{NO}_3^-(\text{aq})$
- D $\text{H}^+(\text{aq})$ and $\text{OH}^-(\text{aq})$.

9. The molecular formula for cyclohexane is

- A C_6H_6
- B C_6H_{10}
- C C_6H_{12}
- D C_6H_{14} .

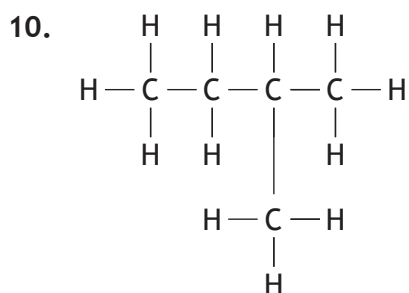

The systematic name for the structure shown is

- A 1,1-dimethylpropane
- B 2-methylbutane
- C 3-methylbutane
- D 2-methylpentane.

11. Petrol is a mixture of hydrocarbons.

The tendency of a hydrocarbon to ignite spontaneously is measured by its octane number.

	<i>Hydrocarbon</i>	<i>Octane number</i>
1	3-methylpentane	74.5
2	butane	93.6
3	pentane	61.7
4	2-methylpentane	73.4
5	hexane	24.8
6	methylcyclopentane	91.3

A student made the hypothesis that as the chain length of a hydrocarbon increases, the octane number decreases.

Which set of three hydrocarbons should have their octane numbers compared in order to test this hypothesis?

- A 1, 4, 6
- B 1, 2, 4
- C 2, 3, 5
- D 3, 4, 5

12. Propene reacts with hydrogen bromide to form two products.

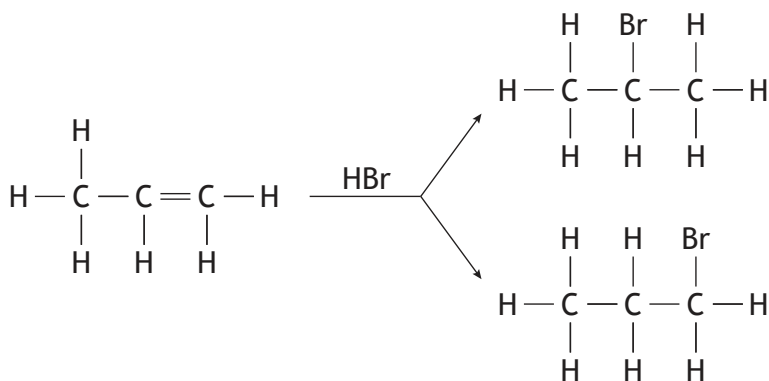

Which of the following alkenes does **not** form two products on reaction with hydrogen bromide?

- A But-1-ene
- B But-2-ene
- C Pent-1-ene
- D Pent-2-ene

13. Which of the following alcohols has the highest boiling point?
You may wish to use your data booklet to help you.
- A Propan-1-ol
 - B Propan-2-ol
 - C Butan-1-ol
 - D Butan-2-ol
14. A reaction is endothermic if
- A energy is required to start the reaction
 - B heat is released during the reaction
 - C the temperature drops during the reaction
 - D the temperature rises during the reaction.
15. Which of the following metals will **not** react with a dilute solution of hydrochloric acid?
- A Copper
 - B Iron
 - C Magnesium
 - D Zinc
16. Which metal can be extracted from its oxide by heat alone?
- A Tin
 - B Zinc
 - C Lead
 - D Silver

17. The ion-electron equations for the oxidation and reduction steps in the reaction between sulfite ions and iron(III) ions are given below.

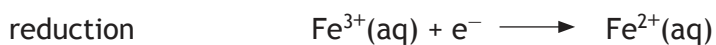
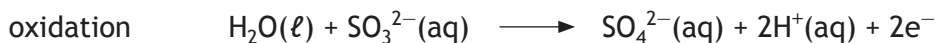

The redox equation for the overall reaction is

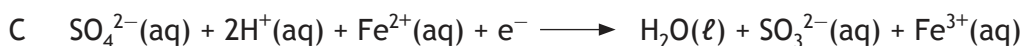
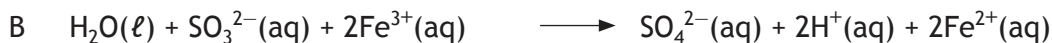
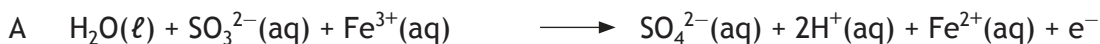

18. The apparatus below was set up.

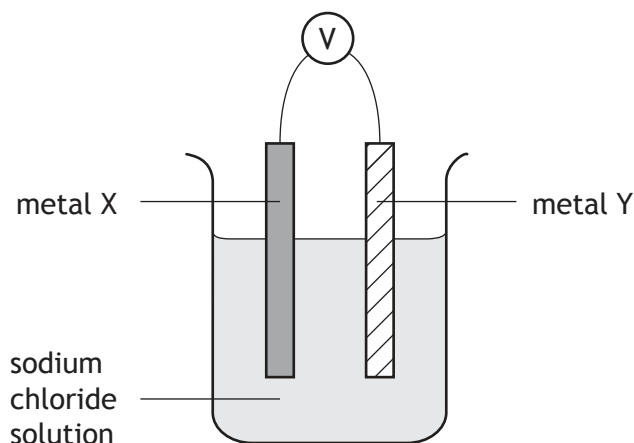

Which of the following pairs of metals would give the highest reading on the voltmeter?

- | | Metal X | Metal Y |
|---|----------------|----------------|
| A | Iron | Zinc |
| B | Magnesium | Silver |
| C | Zinc | Copper |
| D | Zinc | Silver |

[Turn over

19. A section of a condensation polymer is shown below.

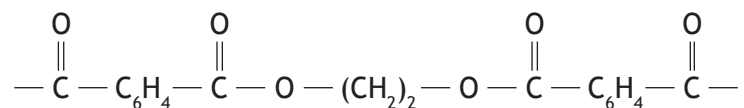

One of the monomers is

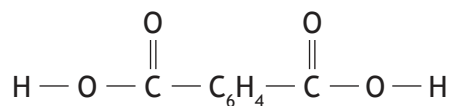

The structural formula for the other monomer is

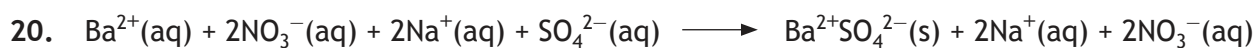
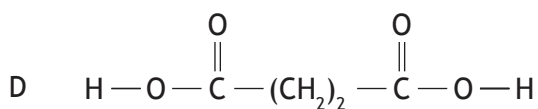
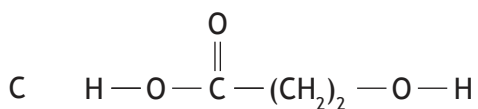
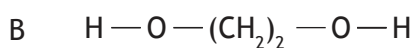
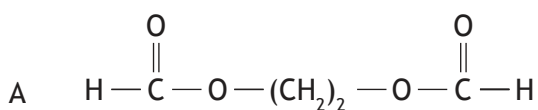

The type of reaction represented by the equation above is

- A addition
- B displacement
- C neutralisation
- D precipitation.

[END OF SECTION 1. NOW ATTEMPT THE QUESTIONS IN SECTION 2 OF YOUR QUESTION AND ANSWER BOOKLET]

FOR OFFICIAL USE



National
Qualifications
2014

Mark

X713/75/01

**Chemistry
Section 1—Answer Grid
And Section 2**

MONDAY, 12 MAY

9:00 AM—11:00 AM



* X 7 1 3 7 5 0 1 *

Fill in these boxes and read what is printed below.

Full name of centre

Town

Forename(s)

Surname

Number of seat

Date of birth

Day

Month

Year

Scottish candidate number

Necessary Data will be found in the Chemistry Data Booklet for National 5.

Total marks—80

SECTION 1—20 marks

Attempt ALL questions in this section.

Instructions for the completion of Section 1 are given on Page two.

SECTION 2—60 marks

Attempt ALL questions in this section.

Write your answers clearly in the spaces provided in this booklet. Additional space for answers and rough work is provided at the end of this booklet. If you use this space you must clearly identify the question number you are attempting. Any rough work must be written in this booklet. You should score through your rough work when you have written your final copy.

Use blue or black ink.

Before leaving the examination room you must give this booklet to the Invigilator; if you do not, you may lose all the marks for this paper.



* X 7 1 3 7 5 0 1 0 1 *

The questions for Section 1 are contained in the question paper X713/75/02.
Read these and record your answers on the answer grid on Page three opposite.
Do NOT use gel pens.

1. The answer to each question is **either** A, B, C or D. Decide what your answer is, then fill in the appropriate bubble (see sample question below).
2. There is **only one correct** answer to each question.
3. Any rough work must be written in the additional space for answers and rough work at the end of this booklet.

Sample Question

To show that the ink in a ball-pen consists of a mixture of dyes, the method of separation would be

- A fractional distillation
- B chromatography
- C fractional crystallisation
- D filtration.

The correct answer is **B**—chromatography. The answer **B** bubble has been clearly filled in (see below).

A	B	C	D
<input type="radio"/>	<input checked="" type="radio"/>	<input type="radio"/>	<input type="radio"/>

Changing an answer

If you decide to change your answer, cancel your first answer by putting a cross through it (see below) and fill in the answer you want. The answer below has been changed to **D**.

A	B	C	D
<input type="radio"/>	<input checked="" type="radio"/>	<input type="radio"/>	<input checked="" type="radio"/>

If you then decide to change back to an answer you have already scored out, put a tick (✓) to the **right** of the answer you want, as shown below:

A	B	C	D	or	A	B	C	D
<input type="radio"/>	<input checked="" type="radio"/>	<input type="radio"/>	<input checked="" type="radio"/>		<input type="radio"/>	<input checked="" type="radio"/>	<input type="radio"/>	<input type="radio"/>



SECTION 1 — Answer Grid



	A	B	C	D
1	<input type="radio"/>	<input type="radio"/>	<input type="radio"/>	<input type="radio"/>
2	<input type="radio"/>	<input type="radio"/>	<input type="radio"/>	<input type="radio"/>
3	<input type="radio"/>	<input type="radio"/>	<input type="radio"/>	<input type="radio"/>
4	<input type="radio"/>	<input type="radio"/>	<input type="radio"/>	<input type="radio"/>
5	<input type="radio"/>	<input type="radio"/>	<input type="radio"/>	<input type="radio"/>
6	<input type="radio"/>	<input type="radio"/>	<input type="radio"/>	<input type="radio"/>
7	<input type="radio"/>	<input type="radio"/>	<input type="radio"/>	<input type="radio"/>
8	<input type="radio"/>	<input type="radio"/>	<input type="radio"/>	<input type="radio"/>
9	<input type="radio"/>	<input type="radio"/>	<input type="radio"/>	<input type="radio"/>
10	<input type="radio"/>	<input type="radio"/>	<input type="radio"/>	<input type="radio"/>
11	<input type="radio"/>	<input type="radio"/>	<input type="radio"/>	<input type="radio"/>
12	<input type="radio"/>	<input type="radio"/>	<input type="radio"/>	<input type="radio"/>
13	<input type="radio"/>	<input type="radio"/>	<input type="radio"/>	<input type="radio"/>
14	<input type="radio"/>	<input type="radio"/>	<input type="radio"/>	<input type="radio"/>
15	<input type="radio"/>	<input type="radio"/>	<input type="radio"/>	<input type="radio"/>
16	<input type="radio"/>	<input type="radio"/>	<input type="radio"/>	<input type="radio"/>
17	<input type="radio"/>	<input type="radio"/>	<input type="radio"/>	<input type="radio"/>
18	<input type="radio"/>	<input type="radio"/>	<input type="radio"/>	<input type="radio"/>
19	<input type="radio"/>	<input type="radio"/>	<input type="radio"/>	<input type="radio"/>
20	<input type="radio"/>	<input type="radio"/>	<input type="radio"/>	<input type="radio"/>



[BLANK PAGE]

DO NOT WRITE ON THIS PAGE



[Turn over for Question 1 on *Page six*

DO NOT WRITE ON THIS PAGE



SECTION 2—60 marks
Attempt ALL questions

MARKS
DO NOT
WRITE IN
THIS
MARGIN

1. In 1911, Ernest Rutherford carried out an experiment to confirm the structure of the atom. In this experiment, he fired positive particles at a very thin layer of gold foil. Most of the particles passed straight through but a small number of the positively charged particles were deflected.

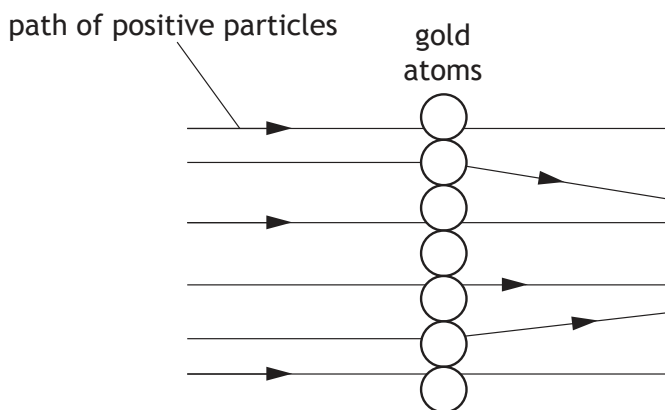

- (a) What caused some of the positive particles to be deflected in this experiment? 1

- (b) Gold is the heaviest element to have only one naturally occurring isotope.

The isotope has a mass number of 197.

- (i) Complete the table to show the number of each type of particle in this gold atom. 1

You may wish to use the data booklet to help you.

Particle	Number
Proton	
Electron	
Neutron	

- (ii) Most elements have more than one isotope.

State what is meant by the term isotope. 1

Total marks 3



2. (a) The properties of a substance depend on its type of bonding and structure. There are four types of bonding and structure.

Discrete covalent molecular	Covalent network	Ionic lattice	Metallic lattice
-----------------------------------	---------------------	------------------	---------------------

Complete the table to match up each type of bonding and structure with its properties.

<i>Type of bonding and structure</i>	<i>Properties</i>
	do not conduct electricity and have high melting points
	have high melting points and conduct electricity when liquid but not when solid
	conduct electricity when solid and have a wide range of melting points
	do not conduct electricity and have low melting points

2

- (b) Graphene is a substance made of a single layer of carbon atoms.



Graphene can conduct electricity.

Suggest what this indicates about some of the electrons in graphene.

1

Total marks 3



* X 7 1 3 7 5 0 1 0 7 *

3. Read the passage below and answer the questions that follow.

Potassium - The Super Element

Potassium is an essential element for almost all living things. The human body requires a regular intake of potassium because humans have no mechanism for storing it. Foods rich in potassium include raisins and almonds. Raisins contain 0.86 g of potassium in every 100 g.

Naturally occurring salts of potassium such as saltpetre (potassium nitrate) and potash (potassium carbonate) have been known for centuries. Potassium salts are used as fertilisers.

Potassium was first isolated by Humphry Davy in 1807. Davy observed that when potassium was added to water it formed globules which skimmed about on the surface, burning with a coloured flame and forming an alkaline solution.

- | | |
|---|---|
| (a) State why the human body requires a regular intake of potassium. | 1 |
| (b) Calculate the number of moles of potassium in 100 g of raisins.
Show your working clearly. | 2 |
| (c) State the colour of the flame which would be seen when potassium burns.
<i>You may wish to use the data booklet to help you.</i> | 1 |
| (d) Write the ionic formula for saltpetre. | 1 |

Total marks 5



MARKSDO NOT
WRITE IN
THIS
MARGIN

4. Poly(vinylcarbazole) is a plastic which conducts electricity when exposed to light.

The structure of the monomer used to make poly(vinylcarbazole) is

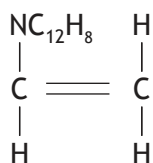

- (a) Draw a section of the polymer showing three monomer units joined together. 1

- (b) Name the type of polymerisation taking place when these monomers join together. 1

Total marks **2**

[Turn over



* X 7 1 3 7 5 0 1 0 9 *

5. Different types of radiation have different penetrating properties. An investigation was carried out using three radioactive sources.

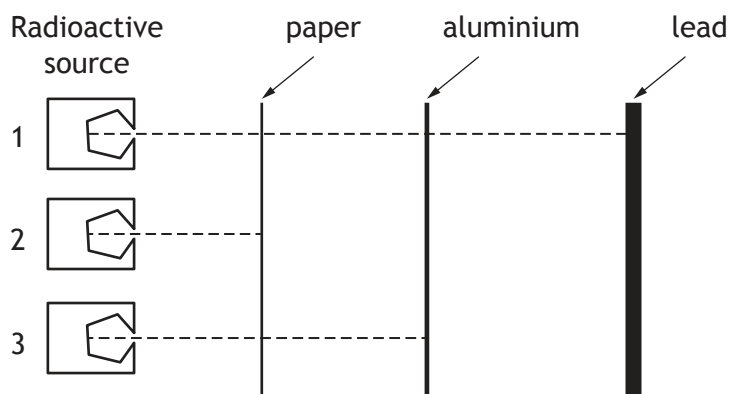

- (a) Name the type of radiation emitted by source 2. 1

- (b) The half-life of source 3 is 8 days.
Calculate the fraction of source 3 that would remain after 16 days. 2
Show your working clearly.

- (c) Radioisotopes can be made by scientists.
The nuclear equation shows how a radioisotope of element X can be made from aluminium.



- Name element X. 1

Total marks 4



MARKS

DO NOT
WRITE IN
THIS
MARGIN

6. A student reacted acidified potassium permanganate solution with oxalic acid, $C_2H_2O_4$.

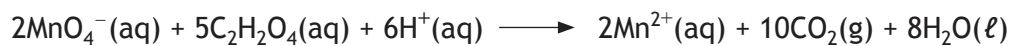

Using your knowledge of chemistry, comment on how the student could have determined the rate of the reaction.

3

[Turn over



* X 7 1 3 7 5 0 1 1 1 *

7. The manufacture of potassium nitrate, for use in fertilisers, can be split into three stages.

(a) (i) In stage 1, ammonia is produced.

Name the industrial process used to manufacture ammonia.

1

(ii) Draw a diagram to show how all the outer electrons are arranged in a molecule of ammonia, NH₃.

1

(b) In stage 2, ammonia is converted into nitric acid, HNO₃, as shown in the flow diagram.

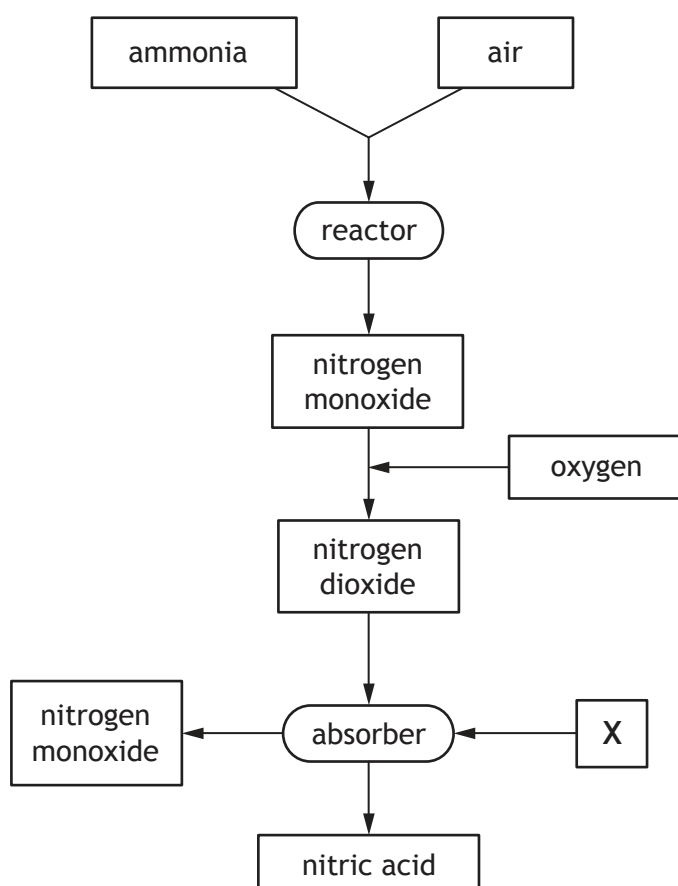

7. (b) (continued)

(i) Name substance X.

1

(ii) On the flow diagram, draw an arrow to show how the process can be made more economical.

1

(c) In stage 3, nitric acid is converted to potassium nitrate.

The equation for the reaction taking place is

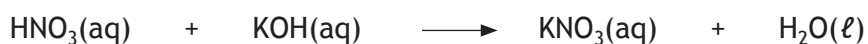

(i) Name the type of chemical reaction taking place in stage 3.

1

(ii) State how a sample of solid potassium nitrate could be obtained from the potassium nitrate solution.

1

Total marks 6

[Turn over



8. Pheromones are chemicals, produced by living things, that trigger a response in members of the same species.

When a bee stings an animal the bee also releases a pheromone containing the ester below.

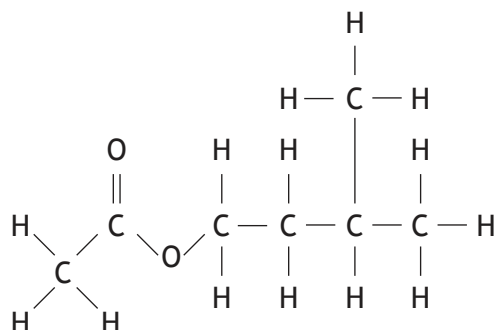

- (a) State another use for esters.

1

- (b) A student made the ester above using ethanoic acid and the following alcohol.

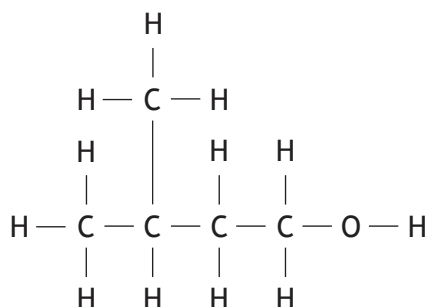

- (i) Name the functional group present in this alcohol.

1

- (ii) Draw a structural formula for an isomer of this alcohol.

1



8. (b) (continued)

(iii) Ethanoic acid is the second member of a family of compounds which contain the carboxyl functional group.

The full structural formulae for the first three members of this family are shown.

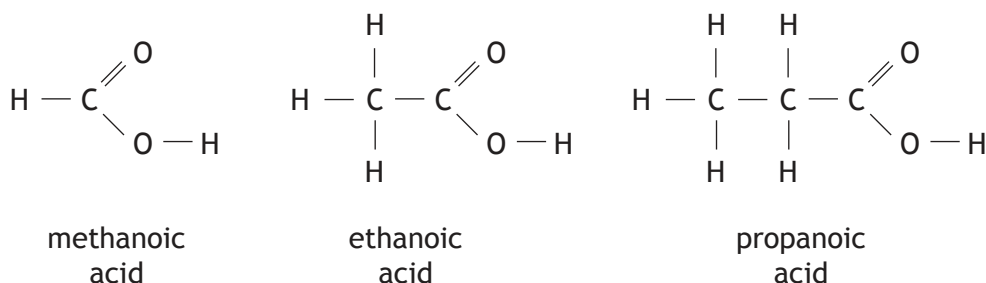

Suggest a general formula for this family of compounds.

1

(c) The table gives information on some other esters.

<i>Alcohol</i>	<i>Carboxylic acid</i>	<i>Ester</i>
methanol	ethanoic acid	methyl ethanoate
propanol	methanoic acid	propyl methanoate
butanol	ethanoic acid	butyl ethanoate
pentanol	butanoic acid	pentyl butanoate
X	Y	ethyl propanoate

Name X and Y.

2

Total marks 6



9. Liquefied petroleum gas (LPG), which can be used as a fuel for heating, is a mixture of propane and butane.

(a) Propane and butane are members of the homologous series of alkanes.

Tick (✓) the **two** boxes that correctly describe members of the same homologous series.

1

	Tick (✓)
They have similar chemical properties.	
They have the same molecular formula.	
They have the same general formula.	
They have the same physical properties.	
They have the same formula mass.	

(b) The table gives some information about propane and butane.

<i>Alkane</i>	<i>Boiling Point (°C)</i>
propane	-42
butane	-1

Explain why butane has a higher boiling point than propane.

2



9. (continued)

- (c) 25 kg of water at 10 °C is heated by burning some LPG.

Calculate the energy, in kJ, required to increase the temperature of the water to 30 °C.

3

You may wish to use the data booklet to help you.

Show your working clearly.

- (d) LPG is odourless. In order to detect gas leaks, ethyl mercaptan, C₂H₆S, a smelly gas, is added in small quantities to the LPG mixture.

Suggest one disadvantage of adding sulfur compounds, such as ethyl mercaptan, to fuels such as LPG.

1

Total marks 7



10. The lowest temperature at which a hydrocarbon ignites is called its flash point.

<i>Hydrocarbon</i>	<i>Flash point (°C)</i>
hexane	-23
heptane	-4
octane	13
nonane	31

- (a) (i) Using the information in the table, make a general statement linking the flash point to the number of carbon atoms. 1
- (ii) Predict the flash point, in °C, of decane, C₁₀H₂₂. 1



10. (continued)

(b) Nonane burns to produce carbon dioxide and water.

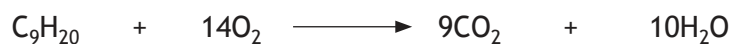

Calculate the mass, in grams, of carbon dioxide produced when 32 g of nonane is burned.

3

Show your working clearly.

Total marks 5

[Turn over



* X 7 1 3 7 5 0 1 1 9 *

11. Chlorine can be produced commercially from concentrated sodium chloride solution in a membrane cell. Only sodium ions can pass through the membrane. These ions move in the direction shown in the diagram.

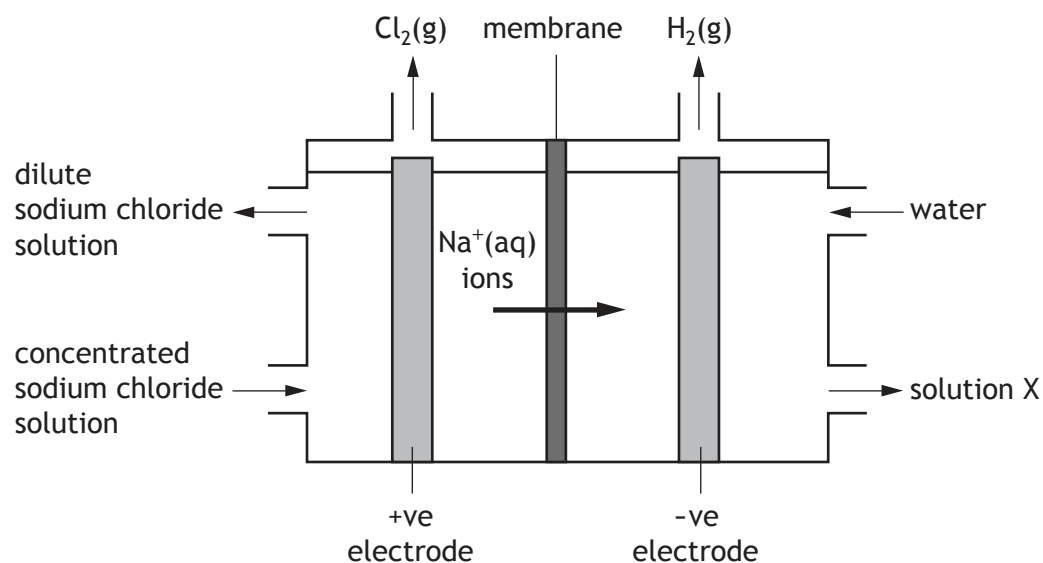

- (a) Write the ion-electron equation for the change taking place at the positive electrode. 1

You may wish to use the data booklet to help you.

- (b) (i) Name solution X. 1

- (ii) The hydrogen gas produced, at the negative electrode, can be used as a fuel.

Suggest an advantage of using hydrogen as a fuel. 1





MARKS DO NOT
WRITE IN
THIS
MARGIN

11. (continued)

- (c) The chlorine gas produced can be used to make phosgene, COCl_2 . Phosgene is used in the manufacture of drugs and plastics.

Draw a possible structure for phosgene.

1

Total marks 4

[Turn over



* X 7 1 3 7 5 0 1 2 1 *

MARKS

DO NOT
WRITE IN
THIS
MARGIN

12. Ores are naturally occurring compounds from which metals can be extracted.

- (a) When a metal is extracted from its ore, metal ions are changed to metal atoms.

Name this type of chemical reaction.

1

- (b) Iron can be extracted from its ore haematite, Fe_2O_3 , in a blast furnace.

Calculate the percentage by mass of iron in haematite.

3

Show your working clearly.

- (c) Magnesium cannot be extracted from its ore in a blast furnace.

Suggest a method that would be suitable for the extraction of magnesium from its ore.

1

Total marks 5



* X 7 1 3 7 5 0 1 2 2 *

13. Sodium carbonate solution can be added to the water in swimming pools to neutralise the acidic effects of chlorine.

A student carried out a titration experiment to determine the concentration of a sodium carbonate solution.

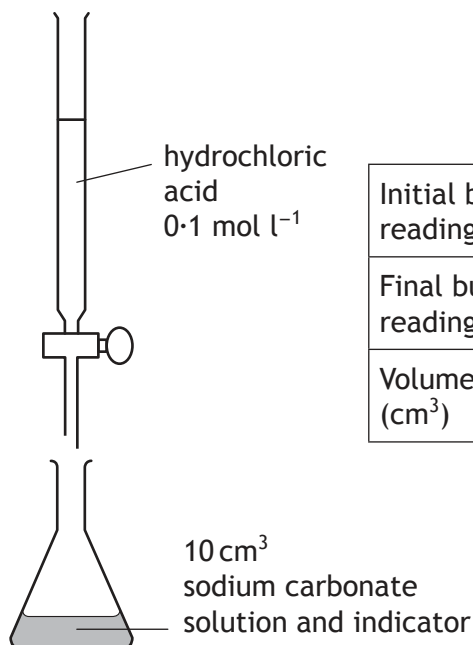

	<i>Rough titre</i>	<i>1st titre</i>	<i>2nd titre</i>
Initial burette reading (cm ³)	0.0	0.0	0.0
Final burette reading (cm ³)	16.5	15.9	16.1
Volume used (cm ³)	16.5	15.9	16.1

- (a) Using the results in the table, calculate the average volume, in cm³, of hydrochloric acid required to neutralise the sodium carbonate solution. 1

- (b) The equation for the reaction is



Using your answer from part (a) calculate the concentration, in mol l⁻¹, of the sodium carbonate solution. 3

Show your working clearly.

Total marks 4



MARKS

DO NOT
WRITE IN
THIS
MARGIN

14. **Chemistry in the cinema.**

In the film Dante's Peak, a family trapped by red hot lava escape by crossing a large lake in a boat made from aluminium. The volcano releases heat and the gases hydrogen chloride, sulfur dioxide and sulfur trioxide into the water in the lake. While crossing the lake, holes begin to appear in the bottom of the boat. Just after the family leave the boat, on the other side of the lake, the boat sinks.

Using your knowledge of chemistry, comment on whether or not the events described in the film could take place.

3

[END OF QUESTION PAPER]



* X 7 1 3 7 5 0 1 2 4 *

ADDITIONAL SPACE FOR ANSWERS AND ROUGH WORK

MARKS

DO NOT
WRITE IN
THIS
MARGIN



* X 7 1 3 7 5 0 1 2 5 *

ADDITIONAL SPACE FOR ANSWERS AND ROUGH WORK

MARKS

DO NOT
WRITE IN
THIS
MARGIN



* X 7 1 3 7 5 0 1 2 6 *

[BLANK PAGE]

DO NOT WRITE ON THIS PAGE



* X 7 1 3 7 5 0 1 2 7 *

Page twenty-seven

[BLANK PAGE]

DO NOT WRITE ON THIS PAGE



* X 7 1 3 7 5 0 1 2 8 *

Page twenty-eight