



National
Qualifications
2016

X713/75/02

**Chemistry
Section 1 — Questions**

WEDNESDAY, 18 MAY

1:00 PM – 3:00 PM

Instructions for the completion of Section 1 are given on *Page 02* of your question and answer booklet X713/75/01.

Record your answers on the answer grid on *Page 03* of your question and answer booklet.

Necessary data will be found in the Chemistry Data Booklet for National 5.

Before leaving the examination room you must give your question and answer booklet to the Invigilator; if you do not, you may lose all the marks for this paper.



* X 7 1 3 7 5 0 2 *

SECTION 1

1. When solid sodium chloride dissolves in water, a solution containing sodium ions and chloride ions is formed.

Which of the following equations correctly shows the state symbols for this process?

- A $\text{NaCl(s)} + \text{H}_2\text{O(l)} \longrightarrow \text{Na}^+(\text{l}) + \text{Cl}^-(\text{l})$
 B $\text{NaCl(s)} + \text{H}_2\text{O(aq)} \longrightarrow \text{Na}^+(\text{aq}) + \text{Cl}^-(\text{aq})$
 C $\text{NaCl(aq)} + \text{H}_2\text{O(l)} \longrightarrow \text{Na}^+(\text{aq}) + \text{Cl}^-(\text{aq})$
 D $\text{NaCl(s)} + \text{H}_2\text{O(l)} \longrightarrow \text{Na}^+(\text{aq}) + \text{Cl}^-(\text{aq})$

2. The table shows the times taken for 0.5 g of magnesium to react completely with acid under different conditions.

<i>Acid concentration</i> (mol l ⁻¹)	<i>Temperature</i> (°C)	<i>Reaction time</i> (s)
0.1	20	80
0.1	25	60
0.2	30	20
0.2	40	10

The time for 0.5 g of magnesium to react completely with 0.2 mol l⁻¹ acid at 25 °C will be

- A less than 10 s
 B between 10 s and 20 s
 C between 20 s and 60 s
 D more than 80 s.
3. When an atom X of an element in Group 1 reacts to become X⁺
- A the mass number of X decreases
 B the atomic number of X increases
 C the charge of the nucleus increases
 D the number of occupied energy levels decreases.
4. Which of the following does **not** contain covalent bonds?
- A Sulfur
 B Copper
 C Oxygen
 D Hydrogen

5. Which of the following structures is **never** found in compounds?

- A Ionic
- B Monatomic
- C Covalent network
- D Covalent molecular

6. Which line in the table shows the properties of an ionic substance?

	<i>Melting point (°C)</i>	<i>Boiling point (°C)</i>	<i>Conducts electricity</i>	
			<i>Solid</i>	<i>Liquid</i>
A	19	80	no	no
B	655	1425	no	no
C	1450	1740	no	yes
D	1495	2927	yes	yes

7. What is the name of the compound with the formula Ag_2O ?

- A Silver(I) oxide
- B Silver(II) oxide
- C Silver(III) oxide
- D Silver(IV) oxide

8. An element was burned in air. The product was added to water, producing a solution with a pH less than 7. The element could be

- A tin
- B zinc
- C sulfur
- D sodium.

9. When methane burns in a plentiful supply of air, the products are

- A carbon and water
- B carbon dioxide and water
- C carbon monoxide and water
- D carbon dioxide and hydrogen.

10. Which of the following compounds belongs to the same homologous series as the compound with the molecular formula C_3H_8 ?

A

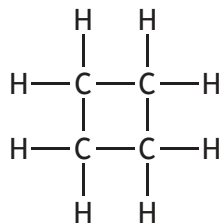

B

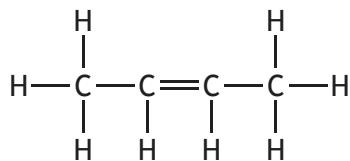

C

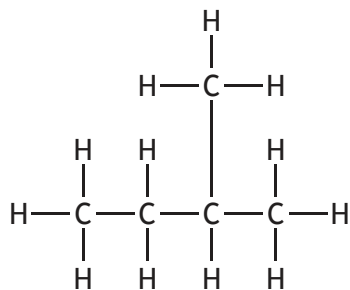

D

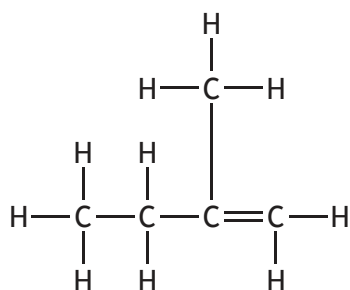

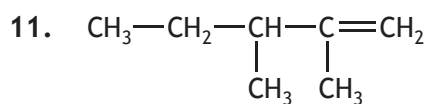

The systematic name for the structure shown is

- A 1,2-dimethylpent-1-ene
- B 2,3-dimethylpent-1-ene
- C 3,4-dimethylpent-4-ene
- D 3,4-dimethylpent-1-ene.

12. Two isomers of butene are

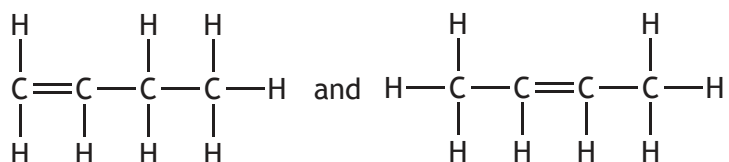

Which of the following structures represents a third isomer of butene?

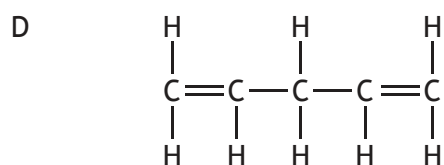
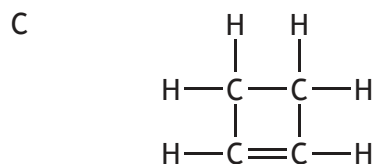
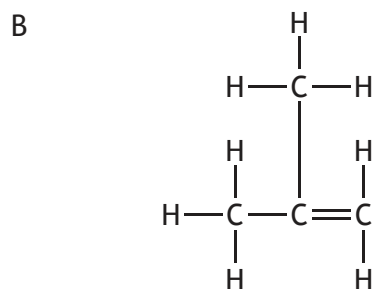
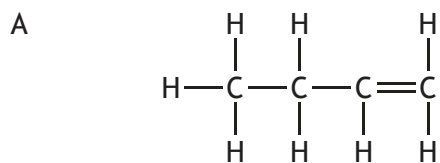

13. Which of the following structures represents an ester?

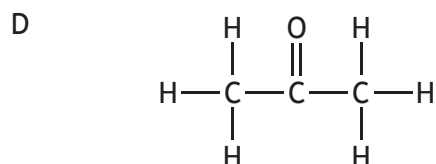
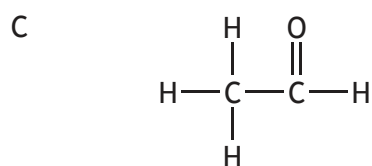
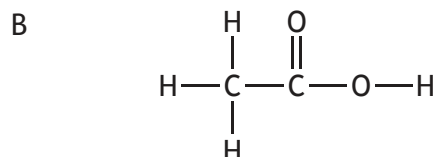
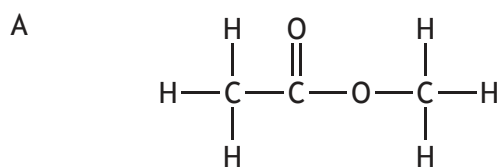

14. The lowest temperature at which a hydrocarbon ignites is called its flash point.

<i>Hydrocarbon</i>	<i>Formula</i>	<i>Boiling point (°C)</i>	<i>Flash point (°C)</i>
hexene	C ₆ H ₁₂	63	-25
hexane	C ₆ H ₁₄	69	-23
cyclohexane	C ₆ H ₁₂	81	-20
heptane	C ₇ H ₁₆	98	-1
octane	C ₈ H ₁₈	126	15

Using information in the table, identify the correct statement.

- A Octane will ignite at 0 °C.
- B Hydrocarbons with the same molecular mass have the same flash point.
- C The flash point of a hydrocarbon increases as the boiling point increases.
- D In a homologous series the flash point decreases as the number of carbon atoms increases.

15. Which of the following metals can be obtained from its ore by heating with carbon monoxide?

You may wish to use the data booklet to help you.

- A Magnesium
- B Aluminium
- C Calcium
- D Nickel

16. Polyesters are always made from monomers

- A which are the same
- B which are unsaturated
- C with one functional group per molecule
- D with two functional groups per molecule.

17. Some smoke detectors make use of radiation which is very easily stopped by tiny smoke particles moving between the radioactive source and the detector.

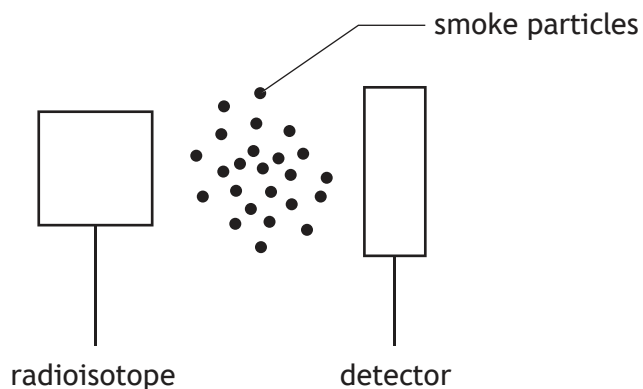

The most suitable type of radioisotope for a smoke detector would be

- A an alpha-emitter with a long half-life
- B a gamma-emitter with a short half-life
- C an alpha-emitter with a short half-life
- D a gamma-emitter with a long half-life.

[Turn over for next question

18. Which particle will be formed when an atom of ${}^{234}_{90}\text{Th}$ emits a β -particle?
- A ${}^{234}_{91}\text{Pa}$
 - B ${}^{230}_{88}\text{Ra}$
 - C ${}^{234}_{89}\text{Ac}$
 - D ${}^{238}_{92}\text{U}$
19. ${}^{14}\text{C}$ has a half life of 5600 years. An analysis of charcoal from a wood fire shows that its ${}^{14}\text{C}$ content is 25 % of that in living wood.
How many years have passed since the wood for the fire was cut?
- A 1400
 - B 4200
 - C 11 200
 - D 16 800
20. A solution of potassium carbonate, made up using tap water, was found to be cloudy. This could result from the tap water containing
- A lithium ions
 - B calcium ions
 - C sodium ions
 - D ammonium ions.

You may wish to use the data booklet to help you.

**[END OF SECTION 1. NOW ATTEMPT THE QUESTIONS IN SECTION 2 OF
YOUR QUESTION AND ANSWER BOOKLET]**



FOR OFFICIAL USE

--	--	--	--	--	--

National
Qualifications
2016

Mark

--

X713/75/01**Chemistry
Section 1 — Answer Grid
And Section 2**

WEDNESDAY, 18 MAY

1:00 PM – 3:00 PM



* X 7 1 3 7 5 0 1 *

Fill in these boxes and read what is printed below.

Full name of centre

Town

--

Forename(s)

Surname

Number of seat

--

--

--

Date of birth

Day

Month

Year

Scottish candidate number

--	--

--	--

--	--

--	--	--	--	--	--	--	--	--	--

Total marks — 80**SECTION 1 — 20 marks**

Attempt ALL questions.

Instructions for the completion of Section 1 are given on Page 02.

SECTION 2 — 60 marks

Attempt ALL questions.

Necessary Data will be found in the Chemistry Data Booklet for National 5.

Write your answers clearly in the spaces provided in this booklet. Additional space for answers and rough work is provided at the end of this booklet. If you use this space you must clearly identify the question number you are attempting. Any rough work must be written in this booklet. You should score through your rough work when you have written your final copy.

Use **blue** or **black** ink.

Before leaving the examination room you must give this booklet to the Invigilator; if you do not, you may lose all the marks for this paper.



* X 7 1 3 7 5 0 1 0 1 *

The questions for Section 1 are contained in the question paper X713/75/02.

Read these and record your answers on the answer grid on *Page 03* opposite.

Use **blue** or **black** ink. Do NOT use gel pens or pencil.

1. The answer to each question is **either** A, B, C or D. Decide what your answer is, then fill in the appropriate bubble (see sample question below).
2. There is **only one correct** answer to each question.
3. Any rough working should be done on the additional space for answers and rough work at the end of this booklet.

Sample Question

To show that the ink in a ball-pen consists of a mixture of dyes, the method of separation would be

- A fractional distillation
- B chromatography
- C fractional crystallisation
- D filtration.

The correct answer is **B** — chromatography. The answer **B** bubble has been clearly filled in (see below).

A	B	C	D
<input type="radio"/>	<input checked="" type="radio"/>	<input type="radio"/>	<input type="radio"/>

Changing an answer

If you decide to change your answer, cancel your first answer by putting a cross through it (see below) and fill in the answer you want. The answer below has been changed to **D**.

A	B	C	D
<input type="radio"/>	<input checked="" type="radio"/>	<input type="radio"/>	<input type="radio"/>
	<input checked="" type="radio"/>		<input checked="" type="radio"/>

If you then decide to change back to an answer you have already scored out, put a tick (✓) to the **right** of the answer you want, as shown below:

A	B	C	D	or	A	B	C	D
<input type="radio"/>	<input checked="" type="radio"/>	<input type="radio"/>	<input checked="" type="radio"/>		<input type="radio"/>	<input checked="" type="radio"/>	<input type="radio"/>	<input type="radio"/>
	<input checked="" type="radio"/>		<input checked="" type="radio"/>			<input checked="" type="radio"/>		



SECTION 1 — Answer Grid



	A	B	C	D
1	<input type="radio"/>	<input type="radio"/>	<input type="radio"/>	<input type="radio"/>
2	<input type="radio"/>	<input type="radio"/>	<input type="radio"/>	<input type="radio"/>
3	<input type="radio"/>	<input type="radio"/>	<input type="radio"/>	<input type="radio"/>
4	<input type="radio"/>	<input type="radio"/>	<input type="radio"/>	<input type="radio"/>
5	<input type="radio"/>	<input type="radio"/>	<input type="radio"/>	<input type="radio"/>
6	<input type="radio"/>	<input type="radio"/>	<input type="radio"/>	<input type="radio"/>
7	<input type="radio"/>	<input type="radio"/>	<input type="radio"/>	<input type="radio"/>
8	<input type="radio"/>	<input type="radio"/>	<input type="radio"/>	<input type="radio"/>
9	<input type="radio"/>	<input type="radio"/>	<input type="radio"/>	<input type="radio"/>
10	<input type="radio"/>	<input type="radio"/>	<input type="radio"/>	<input type="radio"/>
11	<input type="radio"/>	<input type="radio"/>	<input type="radio"/>	<input type="radio"/>
12	<input type="radio"/>	<input type="radio"/>	<input type="radio"/>	<input type="radio"/>
13	<input type="radio"/>	<input type="radio"/>	<input type="radio"/>	<input type="radio"/>
14	<input type="radio"/>	<input type="radio"/>	<input type="radio"/>	<input type="radio"/>
15	<input type="radio"/>	<input type="radio"/>	<input type="radio"/>	<input type="radio"/>
16	<input type="radio"/>	<input type="radio"/>	<input type="radio"/>	<input type="radio"/>
17	<input type="radio"/>	<input type="radio"/>	<input type="radio"/>	<input type="radio"/>
18	<input type="radio"/>	<input type="radio"/>	<input type="radio"/>	<input type="radio"/>
19	<input type="radio"/>	<input type="radio"/>	<input type="radio"/>	<input type="radio"/>
20	<input type="radio"/>	<input type="radio"/>	<input type="radio"/>	<input type="radio"/>



[BLANK PAGE]

DO NOT WRITE ON THIS PAGE



[Turn over for next question

DO NOT WRITE ON THIS PAGE



* X 7 1 3 7 5 0 1 0 5 *

SECTION 2—60 marks
Attempt ALL questions

1. Elements are made up of atoms.

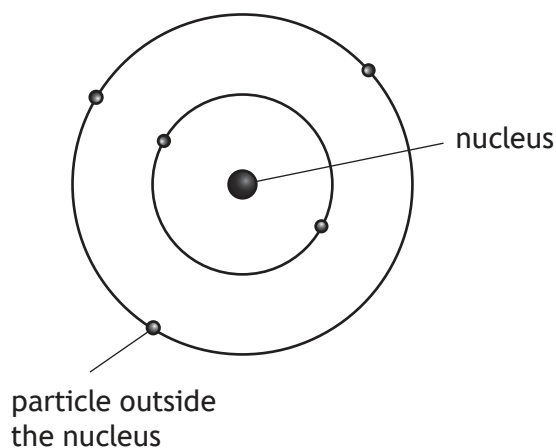

(a) Complete the tables to show the missing information.

(i)

In the Nucleus		
Particle	Relative Mass	Charge
proton		+1
neutron	1	

1

(ii)

Outside the Nucleus		
Particle	Relative Mass	Charge
	almost zero	

1

(b) A sample of nitrogen was found to contain equal amounts of two isotopes. One isotope has mass number 14 and the other has mass number 15.

What is the relative atomic mass of this sample of nitrogen?

1



1. (continued)

(c) Nitrogen can form bonds with other elements.

The diagram shows the shape of a molecule of ammonia (NH₃).

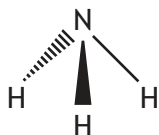

(i) State the name used to describe the shape of a molecule of ammonia. 1

(ii) Name the industrial process used to manufacture ammonia. 1

[Turn over



2. The monomer used to produce polystyrene has the following structure.

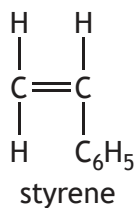

(a) Draw a section of polystyrene, showing three monomer units joined together.

1

(b) When two different monomers polymerise, a copolymer is formed as shown.

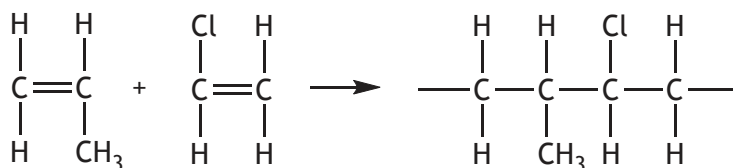

Another copolymer can be made from styrene and acrylonitrile monomers. A section of this copolymer is shown below.

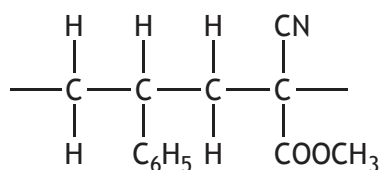

Draw the structure of the acrylonitrile monomer.

1



[Turn over for next question

DO NOT WRITE ON THIS PAGE



* X 7 1 3 7 5 0 1 0 9 *

3. Hydrogen gas can be produced in the laboratory by adding a metal to dilute acid. Heat energy is also produced in the reaction.

(a) State the term used to describe all chemical reactions that release heat energy.

1

(b) A student measured the volume of hydrogen gas produced when zinc lumps were added to dilute hydrochloric acid.

<i>Time (s)</i>	0	10	20	30	40	50	60	70
<i>Volume of hydrogen (cm³)</i>	0	12	21	29	34	36	37	37

(i) Calculate the average rate of reaction, in cm^3s^{-1} , between 10 and 30 seconds.

2

Show your working clearly.

(ii) Estimate the time taken, in seconds, for the reaction to finish.

1

(iii) The student repeated the experiment using the same mass of zinc. State the effect on the rate of the reaction if zinc powder was used instead of lumps.

1



* X 7 1 3 7 5 0 1 1 0 *

3. (continued)

(c) Another student reacted aluminium with dilute nitric acid.



(i) Circle the formula for the salt in the above equation.

1

(ii) 1 mole of hydrogen gas has a volume of 24 litres.

Calculate the volume of hydrogen gas, in litres, produced when 0.01 moles of aluminium react with dilute nitric acid.

2

Show your working clearly.

[Turn over



* X 7 1 3 7 5 0 1 1 1 *

4. Some rocks contain the mineral with the formula Al_2SiO_5 .
This mineral exists in three different forms, andalusite, sillimanite, and kyanite. The form depends on the temperature and pressure.
The diagram shows this relationship.

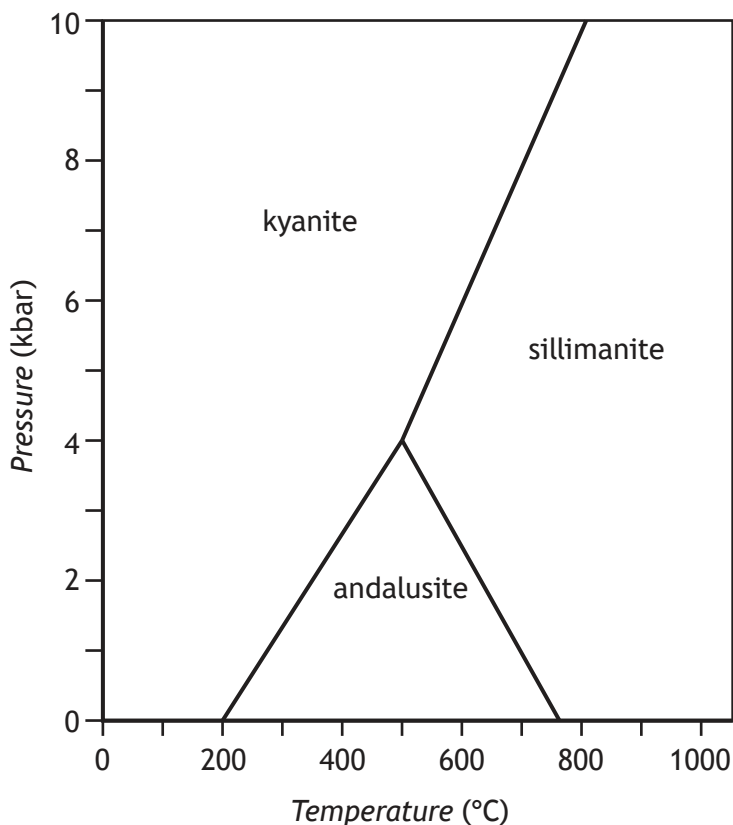

- (a) (i) Name the **two** forms which could exist at 400 °C. 1
- (ii) Complete the table to show the temperature and pressure at which all three forms would exist. 1

Temperature (°C)	
Pressure (kbar)	



MARKS

DO NOT
WRITE IN
THIS
MARGIN

4. (continued)

- (b) Calculate the percentage mass of silicon in andalusite, Al_2SiO_5 .
Show your working clearly.

3

[Turn over



* X 7 1 3 7 5 0 1 1 3 *

5. Read the passage and answer the questions that follow.

Gold — a very useful metal

Gold has been associated with wealth since before the first gold coins were minted in Lydia (modern Turkey) about 550 BC. It does not react with water, air, alkalis and almost all acids. Gold only has one naturally occurring isotope with mass 197.

As an element it has many uses in the modern world. 1 gram of gold can be beaten into a gold film covering one square metre and thin coatings of gold are used as lubricants in aerospace applications. Gold electroplating can be used to coat electrical connectors and printed circuit boards.

Chemists have recently discovered that gold nanoparticles make superb catalysts for many reactions such as the conversion of alcohols into aldehydes and ketones. It can also be used as a catalyst for removing trace carbon monoxide from gases. In this reaction carbon monoxide reacts with oxygen to form carbon dioxide.

Gold nanorods can be grown from a dilute solution of auric acid and are used in the treatment of some forms of cancer.

Adapted from *Education in Chemistry*, Volume 45, November 2008

- (a) Suggest a reason why gold was used in the first coins minted. 1
- (b) Calculate the number of neutrons present in the naturally occurring isotope of gold. 1
- You may wish to use the data booklet to help you.



5. (continued)

- (c) (i) Write an equation, using symbols and formulae, to show the reaction for removing trace carbon monoxide from gases.

There is no need to balance this equation.

1

- (ii) State the role of gold in this reaction.

1

- (d) Circle the correct words to complete the sentence.

1

Gold nanorods can be grown from a solution which contains

more $\left\{ \begin{array}{l} \text{hydroxide} \\ \text{hydrogen} \end{array} \right\}$ ions than $\left\{ \begin{array}{l} \text{hydroxide} \\ \text{hydrogen} \end{array} \right\}$ ions.

[Turn over



6. (a) A fertiliser for tomato plants contains compounds of phosphorus and potassium.

(i) Suggest an experimental test, including the result, to show that potassium is present in the fertiliser.

1

You may wish to use the data booklet to help you.

(ii) Ammonium citrate is included in the fertiliser because some phosphorus compounds are more soluble in ammonium citrate solution than they are in water.

1

Suggest another reason why ammonium citrate is added to the fertiliser.

(b) In the production of the fertiliser ammonium phosphate, phosphoric acid (H_3PO_4) reacts with ammonium hydroxide as shown.



Balance this equation.

1



MARKS

DO NOT
WRITE IN
THIS
MARGIN

7. The element strontium was discovered in 1790 in the village of Strontian in Scotland.

Using your knowledge of chemistry, comment on the chemistry of strontium.

3



* X 7 1 3 7 5 0 1 1 7 *

8. Essential oils can be extracted from plants and used in perfumes and food flavourings.

(a) Essential oils contain compounds called terpenes.

A terpene is a chemical made up of a number of isoprene molecules joined together.

The shortened structural formula of isoprene is $\text{CH}_2\text{C}(\text{CH}_3)\text{CHCH}_2$.

Draw the full structural formula for isoprene.

1

(b) Essential oils can be extracted from the zest of lemons in the laboratory by steam distillation.

The process involves heating up water in a boiling tube until it boils. The steam produced then passes over the lemon zest which is separated from the water by glass wool. As the steam passes over the lemon zest it carries the essential oils into a delivery tube. The condensed liquids (essential oils and water) are collected in a test tube placed in a cold water bath.

Complete the diagram to show the apparatus required to collect the essential oils.

1

(An additional diagram, if required, can be found on Page 29.)

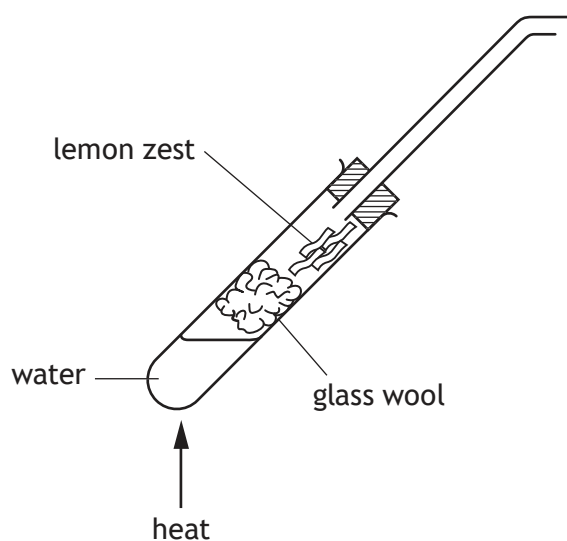

8. (continued)

- (c) Limonene, $C_{10}H_{16}$, is an essential oil which is added to some cleaning products to give them a lemon scent.

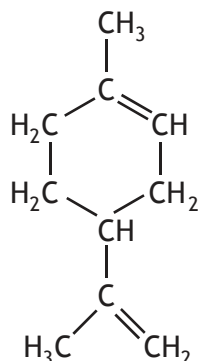

The concentration of limonene present in a cleaning product can be determined by titrating with bromine solution.

- (i) Name the type of chemical reaction taking place when limonene reacts with bromine solution. 1

- (ii) Write the molecular formula for the product formed when limonene, $C_{10}H_{16}$, reacts completely with bromine solution. 1



9. Ethanol can be used as an alternative fuel for cars.
- (a) A student considered two methods to confirm the amount of energy released when ethanol burns.

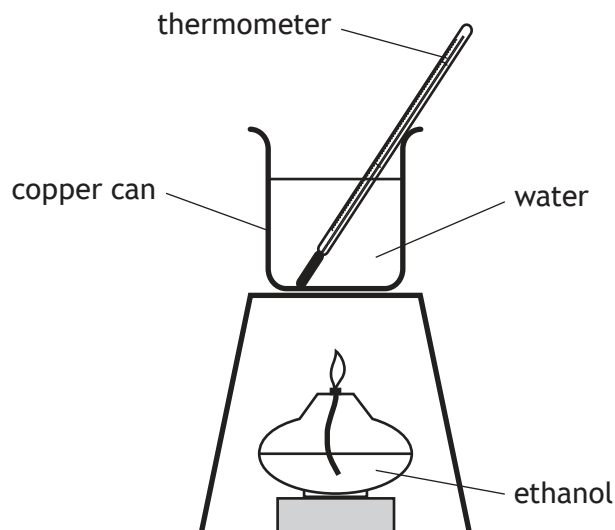

<i>Method A</i>	<i>Method B</i>
1. Record the initial temperature of the water.	1. Record the initial temperature of the water.
2. Weigh the burner containing the fuel.	2. Weigh the burner containing the fuel.
3. Place the burner under the copper can and then light the burner.	3. Light the burner and then place it under the copper can.
4. Extinguish the flame after 2 minutes.	4. Extinguish the flame after 2 minutes.
5. Record the final temperature and reweigh the burner.	5. Record the final temperature and reweigh the burner.

Explain which method would give a more accurate result.

2



9. (continued)

- (b) The table gives information about the amount of energy released when 1 mole of some alcohols are burned.

<i>Name of alcohol</i>	<i>Energy released when one mole of alcohol is burned (kJ)</i>
propan-1-ol	2021
propan-2-ol	2005
butan-1-ol	2676
butan-2-ol	2661
pentan-1-ol	3329
pentan-2-ol	3315
hexan-1-ol	3984

- (i) Write a statement linking the amount of energy released to the position of the functional group in an alcohol molecule. 1

- (ii) Predict the amount of energy released, in kJ, when 1 mole of hexan-2-ol is burned. 1

- (c) Ethanol can also be used in portable camping stoves.

The chemical reaction in a camping stove releases 23 kJ of energy. If 100 g of water is heated using this stove, calculate the rise in temperature of the water, in °C. 3

You may wish to use the data booklet to help you.

Show your working clearly.



10. A battery is a number of cells joined together.

- (a) The diagram shows a simple battery made from copper and zinc discs separated by paper soaked in potassium nitrate solution.

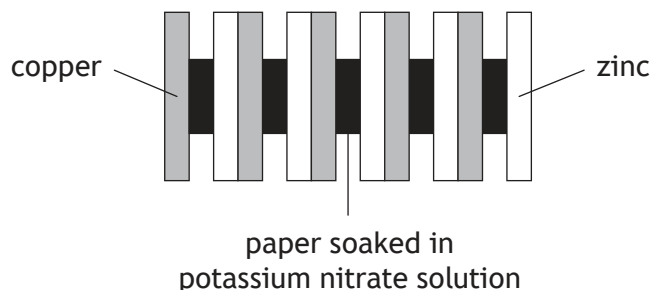

The purpose of the potassium nitrate solution is to complete the circuit.
State the **term** used to describe an ionic compound which is used for this purpose.

1

- (b) A student set up a cell using the same metals as those used in the battery.

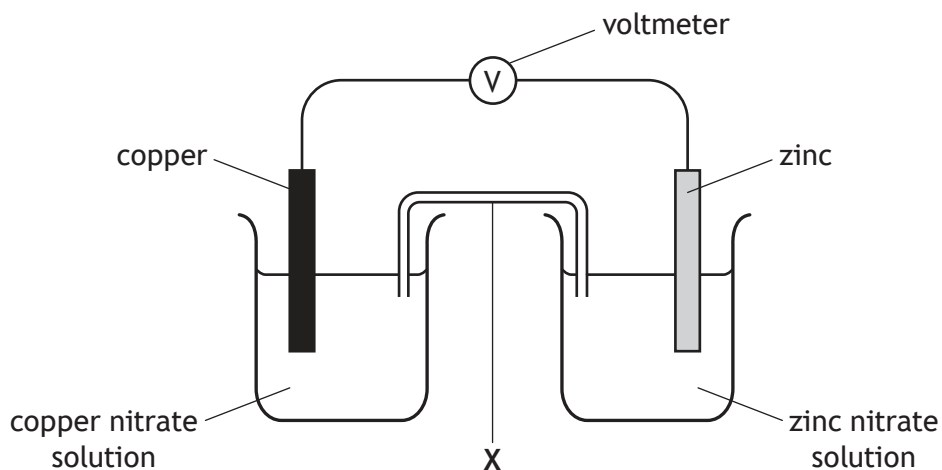

- (i) **On the diagram**, draw an arrow to show the path and direction of electron flow.

1

You may wish to use the data booklet to help you.

- (ii) Name the piece of apparatus labelled X.

1



10. (continued)

(c) Electricity can also be produced in a cell containing non-metals.

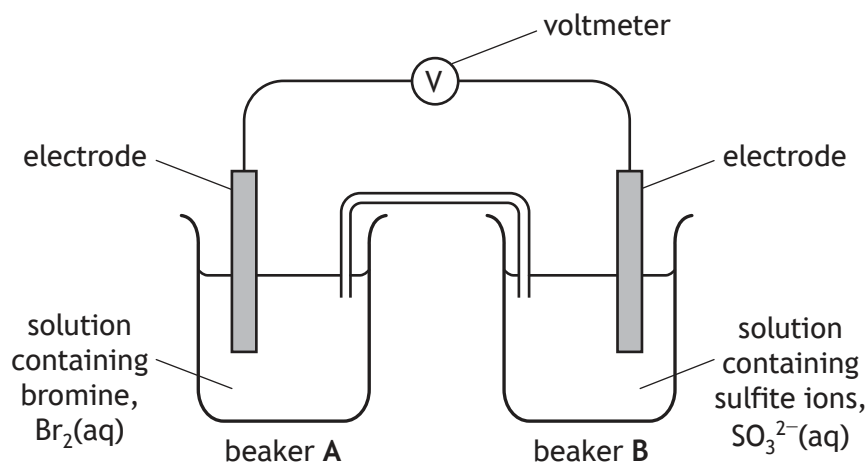

The reactions occurring at each electrode are

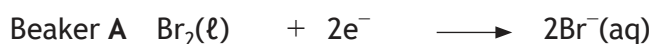

(i) Name the type of chemical reaction taking place in beaker B. 1

(ii) Write the redox equation for the overall reaction. 1

(iii) Name a non-metal element which is suitable for use as the electrodes. 1



11. Ethers are a group of compounds containing carbon, hydrogen and oxygen.

<i>Name of ether</i>	<i>Structural formula</i>	<i>Boiling point (°C)</i>
methoxyethane	$\text{CH}_3 - \text{O} - \text{CH}_2\text{CH}_3$	7
ethoxyethane	$\text{CH}_3\text{CH}_2 - \text{O} - \text{CH}_2\text{CH}_3$	35
X	$\text{CH}_3 - \text{O} - \text{CH}_2\text{CH}_2\text{CH}_3$	39
propoxybutane	$\text{CH}_3\text{CH}_2\text{CH}_2 - \text{O} - \text{CH}_2\text{CH}_2\text{CH}_2\text{CH}_3$	117

(a) Name ether X. 1

(b) Suggest a general formula for this homologous series. 1

(c) Methoxyethane is a covalent molecular substance. It has a low boiling point and is a gas at room temperature.

Circle the correct words to complete the sentence. 1

The bonds between the molecules are $\left\{ \begin{array}{l} \text{weak} \\ \text{strong} \end{array} \right\}$ and the bonds

within the molecule are $\left\{ \begin{array}{l} \text{weak} \\ \text{strong} \end{array} \right\}$.



11. (continued)

(d) Epoxides are a family of cyclic ethers.

The full structural formula for the first member of this family is shown.

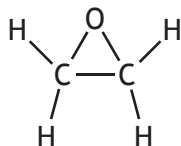

(i) Epoxides can be produced by reacting an alkene with oxygen.

Name the alkene which would be used to produce the epoxide shown.

1

(ii) Epoxides have three atoms in a ring, one of which is oxygen.

Draw a structural formula for the epoxide with the chemical formula C_3H_6O .

1



12. Betanin is responsible for the red colour in beetroot and can be used as a food colouring.

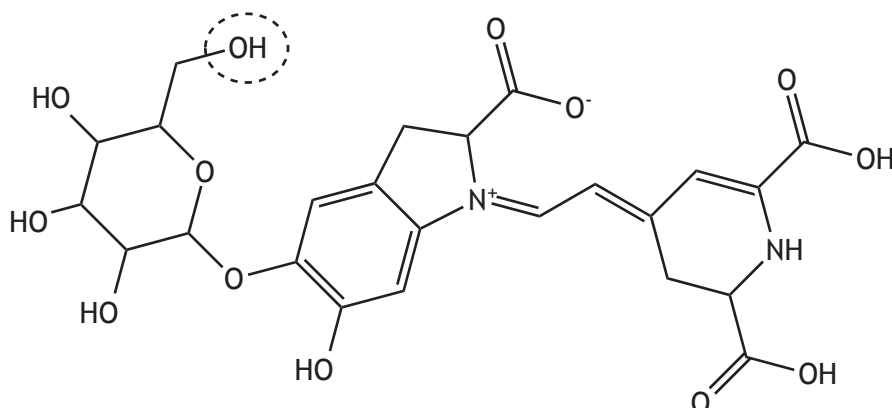

- (a) Name the functional group circled in the diagram above. 1
- (b) Betanin can be used as an indicator in a neutralisation reaction.
The pH range at which some indicators change colour is shown.

<i>Indicator</i>	<i>pH range of colour change</i>
methyl orange	3.2 to 4.4
litmus	5.0 to 8.0
phenolphthalein	8.2 to 10.0
betanin	9.0 to 10.0

The indicator used in a neutralisation reaction depends on the pH at the end point.

The table below shows the end point of neutralisation reactions using different types of acid and base.

<i>Type of acid</i>	<i>Type of base</i>	<i>pH at the end point</i>
strong	strong	7
strong	weak	below 7
weak	strong	above 7

Betanin can be used to indicate the end point in the reaction between oxalic acid and sodium hydroxide solution.

State the type of acid and the type of base used in this reaction. 1

12. (continued)

MARKS
DO NOT
WRITE IN
THIS
MARGIN

- (c) A student carried out a titration experiment to determine the concentration of a sodium hydroxide solution.

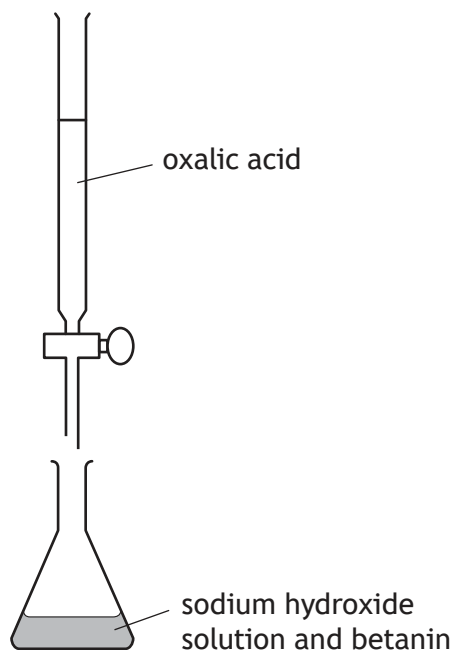

	<i>Initial burette reading (cm³)</i>	<i>Final burette reading (cm³)</i>	<i>Volume used (cm³)</i>
Rough titre	0.0	15.6	15.6
1st titre	15.6	30.5	14.9
2nd titre	30.5	45.6	15.1

Using the results in the table, calculate the average volume, in cm³, of oxalic acid required to neutralise the sodium hydroxide solution.

1

- (d) Oxalic acid is found naturally in rhubarb. A piece of rhubarb was found to contain 1.8 g of oxalic acid.

Calculate the number of moles of oxalic acid contained in the piece of rhubarb.

1

(Formula mass of oxalic acid = 90)



* X 7 1 3 7 5 0 1 2 7 *

13. Carbonated water, also known as sparkling water, is water into which carbon dioxide gas has been dissolved. This process is called carbonating.

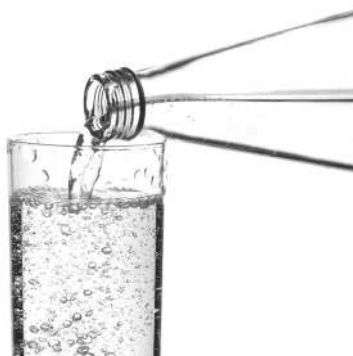

A group of students are given two brands of carbonated water and asked to determine which brand contains more dissolved carbon dioxide.

Using your knowledge of chemistry, describe how the students could determine which brand of carbonated water contains more dissolved carbon dioxide.

3

[END OF QUESTION PAPER]



* X 7 1 3 7 5 0 1 2 8 *

ADDITIONAL SPACE FOR ANSWERS

Additional diagram for Question 8 (b)

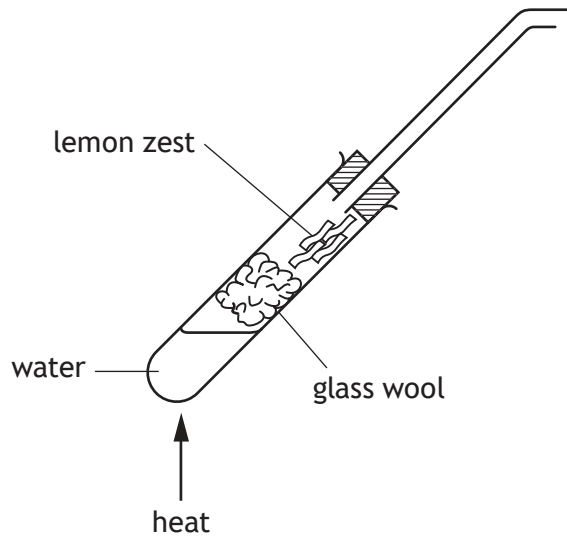

MARKS

DO NOT
WRITE IN
THIS
MARGIN

ADDITIONAL SPACE FOR ANSWERS AND ROUGH WORK



* X 7 1 3 7 5 0 1 3 0 *

MARKS DO NOT
WRITE IN
THIS
MARGIN

ADDITIONAL SPACE FOR ANSWERS AND ROUGH WORK



* X 7 1 3 7 5 0 1 3 1 *

ACKNOWLEDGEMENTS

Section 2 Question 5 – Passage is adapted from “The Elements – Gold” taken from *Education in Chemistry, Volume 45, November 2008*. Reproduced by permission of Royal Society of Chemistry.

Section 2 Question 13 – Alexey Lysenko/shutterstock.com



* X 7 1 3 7 5 0 1 3 2 *