



National
Qualifications
2018

X813/75/02

**Chemistry
Section 1 — Questions**

MONDAY, 21 MAY

1:00 PM – 3:30 PM

Instructions for completion of Section 1 are given on *page 02* of your question and answer booklet X813/75/01.

Record your answers on the answer grid on *page 03* of your question and answer booklet.

You may refer to the Chemistry Data Booklet for National 5.

Before leaving the examination room you must give your question and answer booklet to the Invigilator; if you do not, you may lose all the marks for this paper.



* X 8 1 3 7 5 0 2 *

SECTION 1 — 25 marks

Attempt ALL questions

1. Which of the following changes would **not** speed up a chemical reaction?

- A Increasing the particle size
- B Increasing the temperature
- C Increasing the concentration
- D Addition of a catalyst

2. Which line in the table identifies the correct location of a proton and an electron in an atom?

	<i>Proton</i>	<i>Electron</i>
A	inside the nucleus	inside the nucleus
B	inside the nucleus	outside the nucleus
C	outside the nucleus	outside the nucleus
D	outside the nucleus	inside the nucleus

3. Which of the following elements does **not** exist as diatomic molecules?

- A Oxygen
- B Helium
- C Bromine
- D Hydrogen

4. The shapes of some molecules are shown below.



tetrahedral



trigonal
pyramidal

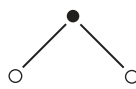

angular



linear

The shape of a molecule of hydrogen bromide is likely to be

- A tetrahedral
- B trigonal pyramidal
- C angular
- D linear.

5. Which of the following elements forms an ion with a single positive charge and an electron arrangement of 2,8?

You may wish to use the data booklet to help you.

- A Sodium
- B Magnesium
- C Fluorine
- D Neon

6. Which line in the table shows the properties of a covalent network compound?

	Melting point (°C)	Boiling point (°C)	Conducts electricity	
			Solid	Liquid
A	-127	-100	no	no
B	795	1410	no	yes
C	30	2204	yes	yes
D	2700	3350	no	no

7. 0.1 mol of sodium hydroxide was dissolved in water and the solution made up to 250 cm³. What is the concentration, in mol l⁻¹, of the sodium hydroxide solution?

- A 0.0004
- B 0.025
- C 0.4
- D 2.5

8. An alkaline solution contains

- A only hydroxide ions
- B more hydroxide ions than hydrogen ions
- C more hydrogen ions than hydroxide ions
- D equal numbers of hydrogen ions and hydroxide ions.

[Turn over

9. A student made some statements about the effect of adding water to an acidic solution. Identify the correct statement.

- A The pH of the solution will remain the same.
- B The pH of the solution will decrease.
- C The hydrogen ion concentration will decrease.
- D The hydrogen ion concentration will increase.

10. The shortened structural formula for a compound is



Which of the following is another way of representing this structure?

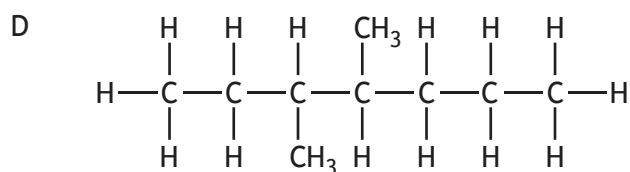
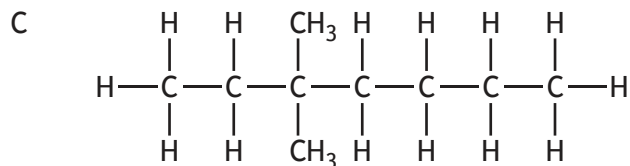
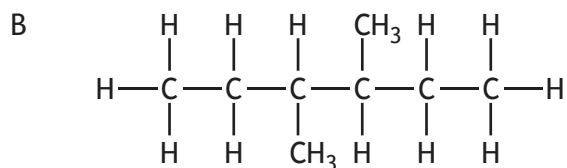
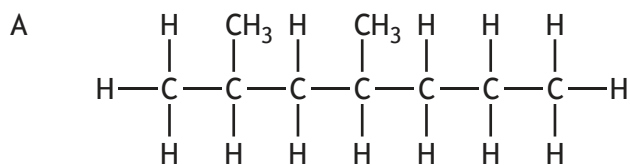

12. Which of the following reactions takes place when an alcohol is formed from an alkene?

- A Hydrogenation
- B Combustion
- C Hydration
- D Reduction

13.

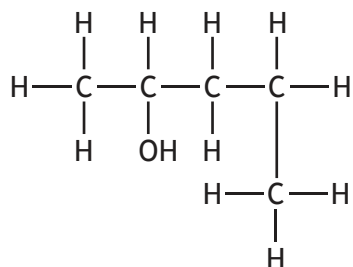

The systematic name for the above compound is

- A pentan-2-ol
- B pentan-4-ol
- C 1-methylbutan-3-ol
- D 4-methylbutan-2-ol.

14. Which of the following alcohols is the least soluble in water?

- A Butan-1-ol
- B Hexan-1-ol
- C Pentan-1-ol
- D Propan-1-ol

15. A student set up an experiment to determine the quantity of energy released when a hydrocarbon burns.
- Which of the following diagrams shows the apparatus which would produce the most accurate result?

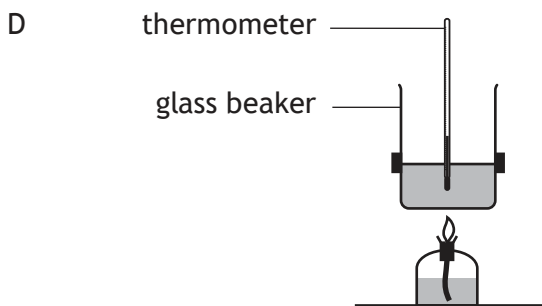
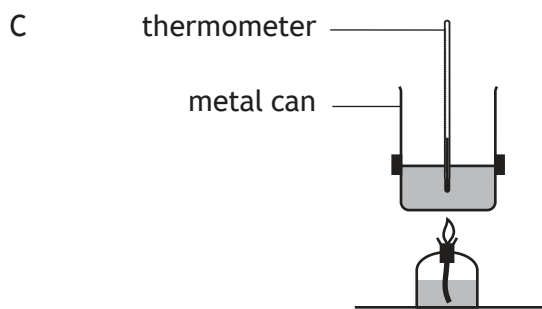
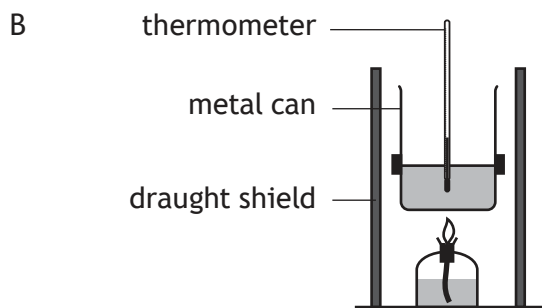
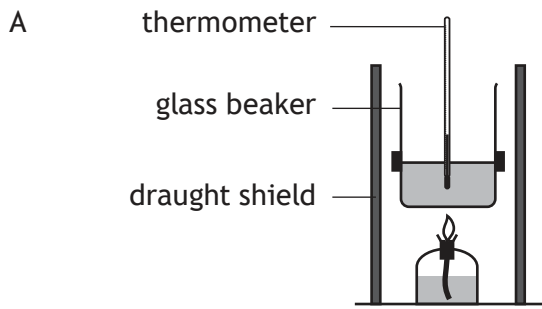

[Turn over

16. The ether, 1-ethoxypropane, can be made by the Williamson reaction.

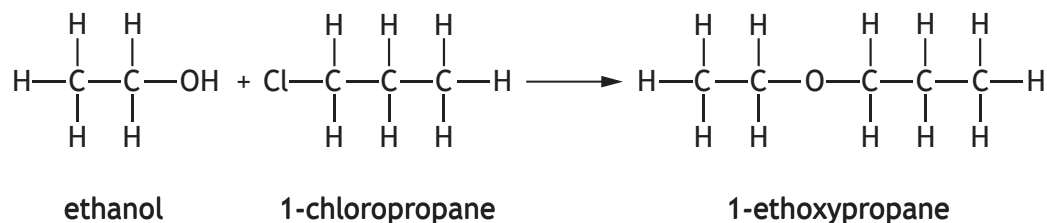

The structural formula for another ether is shown below.

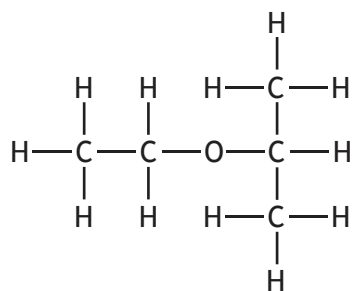

2-ethoxypropane

Which of the following pairs of compounds would react together to produce 2-ethoxypropane?

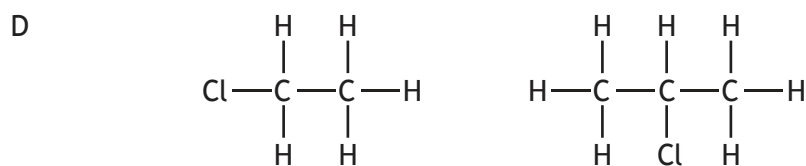
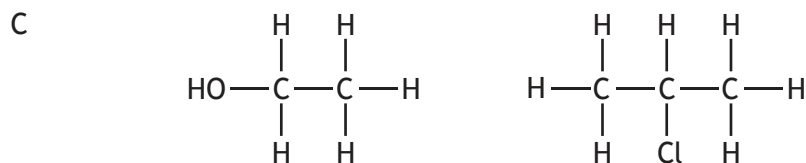
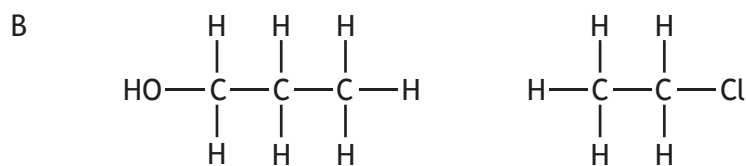
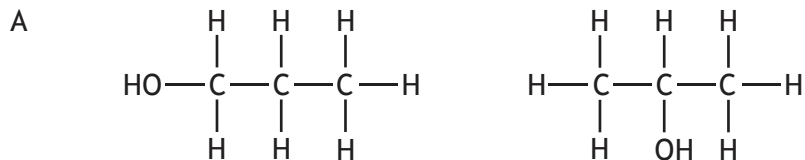

17. Information about the reactions of four different metals, W, X, Y and Z is given in the table.

<i>Metal</i>	<i>Reaction with dilute acid</i>	<i>Reaction with water</i>
W	moderate reaction	no reaction
X	fast reaction	slow reaction
Y	slow reaction	no reaction
Z	fast reaction	no reaction

The order of reactivity of the metals, starting with the most reactive is

- A X, Z, W, Y
- B Y, W, Z, X
- C Z, X, W, Y
- D Y, W, X, Z.

18. The ion-electron equations for the oxidation and reduction steps in the reaction between hydrogen and oxygen are given below.



The redox equation for the overall reaction is

- A $\text{H}_2(\text{g}) + 2\text{H}_2\text{O}(\ell) + \text{O}_2(\text{g}) + 4\text{e}^- \rightarrow 2\text{H}^+(\text{aq}) + 4\text{OH}^-(\text{aq}) + 2\text{e}^-$
- B $2\text{H}_2(\text{g}) + 2\text{H}_2\text{O}(\ell) + \text{O}_2(\text{g}) \rightarrow 4\text{H}^+(\text{aq}) + 4\text{OH}^-(\text{aq})$
- C $\text{H}_2(\text{g}) + 2\text{H}_2\text{O}(\ell) + \text{O}_2(\text{g}) \rightarrow 2\text{H}^+(\text{aq}) + 4\text{OH}^-(\text{aq})$
- D $2\text{H}_2(\text{g}) + 2\text{H}_2\text{O}(\ell) + \text{O}_2(\text{g}) + 4\text{e}^- \rightarrow 4\text{H}^+(\text{aq}) + 4\text{OH}^-(\text{aq}) + 4\text{e}^-$

[Turn over

19. Which of the following metals, when connected to lead in a cell, would produce the highest reading on the voltmeter?

You may wish to use the data booklet to help you.

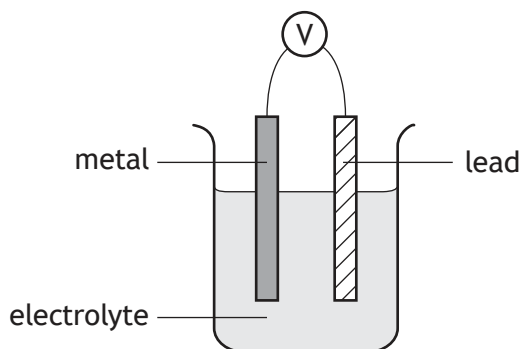

- A Zinc
 - B Tin
 - C Nickel
 - D Lead
20. Which of the following salts would **not** be used as a fertiliser?

- A Ammonium chloride
- B Ammonium phosphate
- C Sodium chloride
- D Sodium phosphate

21. Which metal is used as the catalyst in the industrial manufacture of ammonia?

- A Nickel
- B Platinum
- C Iron
- D Rhodium

22. The diagram shows the path of two different types of radiation as they pass through an electric field.

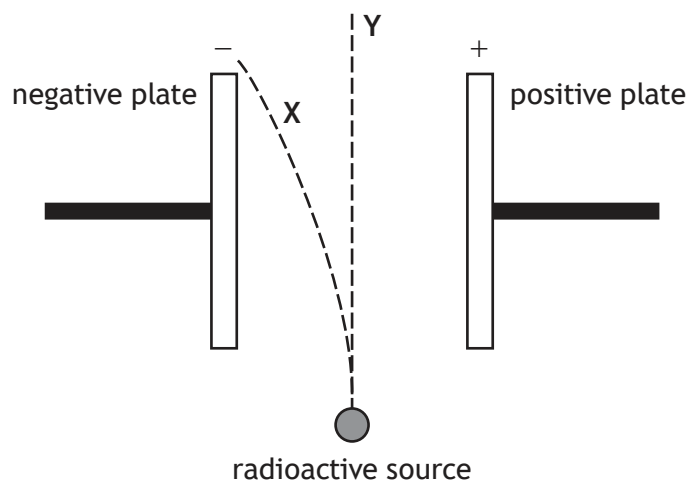

Which line in the table correctly identifies the types of radiation which follow paths X and Y?

	<i>Path X</i>	<i>Path Y</i>
A	alpha	beta
B	beta	alpha
C	beta	gamma
D	alpha	gamma

23. Metallic bonding is a force of attraction between

- A a shared pair of electrons and two nuclei
- B negative ions and delocalised electrons
- C negative ions and positive ions
- D positive ions and delocalised electrons.

[Turn over

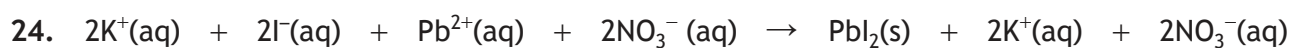

The type of reaction represented by this equation is

- A neutralisation
- B precipitation
- C addition
- D redox.

25. A student prepared a sample of copper sulfate crystals by reacting excess copper carbonate with acid.

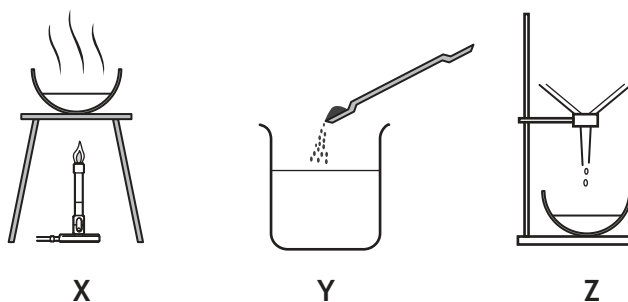

Which line in the table shows the correct order in which this experiment would be carried out?

- A Y, X, Z
- B X, Y, Z
- C Z, Y, X
- D Y, Z, X

[END OF SECTION 1. NOW ATTEMPT THE QUESTIONS IN SECTION 2 OF
YOUR QUESTION AND ANSWER BOOKLET]

FOR OFFICIAL USE



National
Qualifications
2018

Mark

X813/75/01

**Chemistry
Section 1 — Answer Grid
and Section 2**

MONDAY, 21 MAY

1:00 PM – 3:30 PM



* X 8 1 3 7 5 0 1 *

Fill in these boxes and read what is printed below.

Full name of centre

Town

Forename(s)

Surname

Number of seat

Date of birth

Day

Month

Year

Scottish candidate number

Total marks — 100

SECTION 1 — 25 marks

Attempt ALL questions.

Instructions for the completion of Section 1 are given on *page 02*.

SECTION 2 — 75 marks

Attempt ALL questions.

You may refer to the Chemistry Data Booklet for National 5.

Write your answers clearly in the spaces provided in this booklet. Additional space for answers and rough work is provided at the end of this booklet. If you use this space you must clearly identify the question number you are attempting. Any rough work must be written in this booklet. You should score through your rough work when you have written your final copy.

Use **blue** or **black** ink.

Before leaving the examination room you must give this booklet to the Invigilator; if you do not, you may lose all the marks for this paper.



* X 8 1 3 7 5 0 1 0 1 *

The questions for Section 1 are contained in the question paper X813/75/02.

Read these and record your answers on the answer grid on *page 03* opposite.

Use **blue** or **black** ink. Do NOT use gel pens or pencil.

1. The answer to each question is **either** A, B, C or D. Decide what your answer is, then fill in the appropriate bubble (see sample question below).
2. There is **only one correct** answer to each question.
3. Any rough working should be done on the additional space for answers and rough work at the end of this booklet.

Sample question

To show that the ink in a ball-pen consists of a mixture of dyes, the method of separation would be

- A fractional distillation
- B chromatography
- C fractional crystallisation
- D filtration.

The correct answer is **B** — chromatography. The answer **B** bubble has been clearly filled in (see below).

A	B	C	D
<input type="radio"/>	<input checked="" type="radio"/>	<input type="radio"/>	<input type="radio"/>

Changing an answer

If you decide to change your answer, cancel your first answer by putting a cross through it (see below) and fill in the answer you want. The answer below has been changed to **D**.

A	B	C	D
<input type="radio"/>	<input checked="" type="radio"/>	<input type="radio"/>	<input type="radio"/>

If you then decide to change back to an answer you have already scored out, put a tick (✓) to the **right** of the answer you want, as shown below:

A	B	C	D	or	A	B	C	D
<input type="radio"/>	<input checked="" type="radio"/>	<input type="radio"/>	<input checked="" type="radio"/>		<input type="radio"/>	<input checked="" type="radio"/>	<input type="radio"/>	<input type="radio"/>



SECTION 1 — Answer Grid



* O B J 2 5 A D 1 *

	A	B	C	D
1	<input type="radio"/>	<input type="radio"/>	<input type="radio"/>	<input type="radio"/>
2	<input type="radio"/>	<input type="radio"/>	<input type="radio"/>	<input type="radio"/>
3	<input type="radio"/>	<input type="radio"/>	<input type="radio"/>	<input type="radio"/>
4	<input type="radio"/>	<input type="radio"/>	<input type="radio"/>	<input type="radio"/>
5	<input type="radio"/>	<input type="radio"/>	<input type="radio"/>	<input type="radio"/>
6	<input type="radio"/>	<input type="radio"/>	<input type="radio"/>	<input type="radio"/>
7	<input type="radio"/>	<input type="radio"/>	<input type="radio"/>	<input type="radio"/>
8	<input type="radio"/>	<input type="radio"/>	<input type="radio"/>	<input type="radio"/>
9	<input type="radio"/>	<input type="radio"/>	<input type="radio"/>	<input type="radio"/>
10	<input type="radio"/>	<input type="radio"/>	<input type="radio"/>	<input type="radio"/>
11	<input type="radio"/>	<input type="radio"/>	<input type="radio"/>	<input type="radio"/>
12	<input type="radio"/>	<input type="radio"/>	<input type="radio"/>	<input type="radio"/>
13	<input type="radio"/>	<input type="radio"/>	<input type="radio"/>	<input type="radio"/>
14	<input type="radio"/>	<input type="radio"/>	<input type="radio"/>	<input type="radio"/>
15	<input type="radio"/>	<input type="radio"/>	<input type="radio"/>	<input type="radio"/>
16	<input type="radio"/>	<input type="radio"/>	<input type="radio"/>	<input type="radio"/>
17	<input type="radio"/>	<input type="radio"/>	<input type="radio"/>	<input type="radio"/>
18	<input type="radio"/>	<input type="radio"/>	<input type="radio"/>	<input type="radio"/>
19	<input type="radio"/>	<input type="radio"/>	<input type="radio"/>	<input type="radio"/>
20	<input type="radio"/>	<input type="radio"/>	<input type="radio"/>	<input type="radio"/>
21	<input type="radio"/>	<input type="radio"/>	<input type="radio"/>	<input type="radio"/>
22	<input type="radio"/>	<input type="radio"/>	<input type="radio"/>	<input type="radio"/>
23	<input type="radio"/>	<input type="radio"/>	<input type="radio"/>	<input type="radio"/>
24	<input type="radio"/>	<input type="radio"/>	<input type="radio"/>	<input type="radio"/>
25	<input type="radio"/>	<input type="radio"/>	<input type="radio"/>	<input type="radio"/>



* X 8 1 3 7 5 0 1 0 3 *

[BLANK PAGE]

DO NOT WRITE ON THIS PAGE



* X 8 1 3 7 5 0 1 0 4 *

[Turn over for next question

DO NOT WRITE ON THIS PAGE



* X 8 1 3 7 5 0 1 0 5 *

SECTION 2 — 75 marks

Attempt ALL questions

1. A student monitored the rate of reaction between excess calcium carbonate and dilute hydrochloric acid, HCl, using a gas syringe to collect the gas produced.

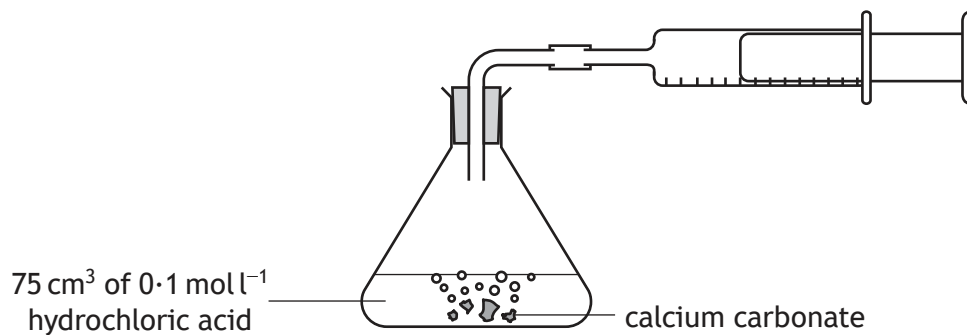

- (a) Name the gas produced in this reaction.

1

- (b) The student obtained the results shown.

<i>Time (s)</i>	0	10	20	40	50	60	70	80
<i>Volume of gas (cm³)</i>	0	48	62	74	77	79	80	80

- (i) Calculate the average rate of reaction between 20 and 50 seconds.

3

Your answer must include the appropriate unit.

Show your working clearly.



* X 8 1 3 7 5 0 1 0 6 *

1. (b) (continued)

(ii) Draw a graph of the student's results.

4

(Additional graph paper, if required, can be found on page 33).

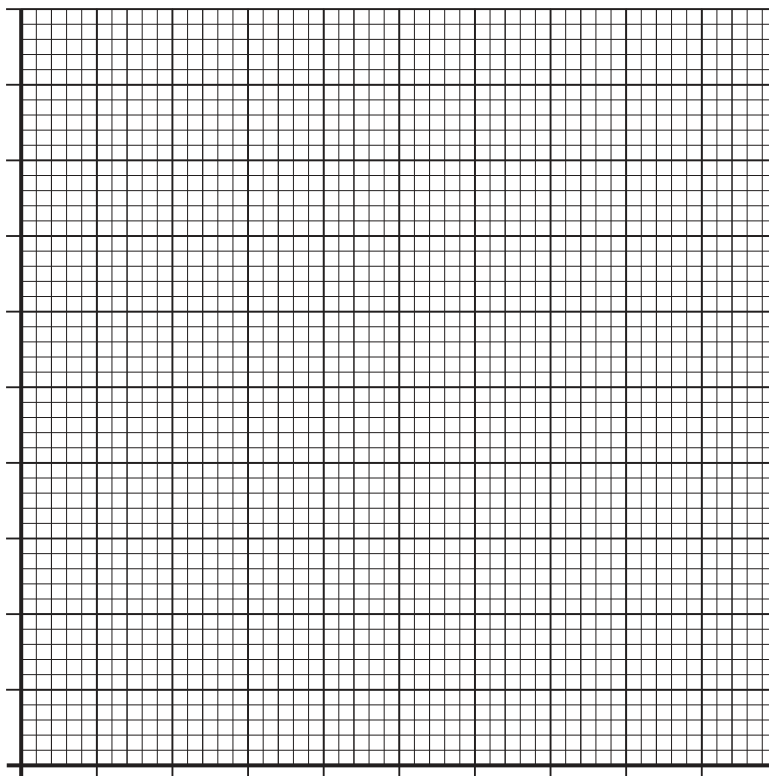

(iii) Using your graph, estimate the volume of gas, in cm^3 , produced at 30 seconds.

1

(c) The student carried out a similar experiment using 75 cm^3 of 0.1 mol l^{-1} sulfuric acid, $\text{H}_2\text{SO}_4(\text{aq})$.

The total volume of gas collected was 160 cm^3 .

Explain why there was a greater volume of gas produced.

1



2. The retractable roof on Centre Court at Wimbledon Tennis Club is made of the polymer poly(tetrafluoroethene), PTFE.

(a) The monomer used to produce PTFE has the following structure.

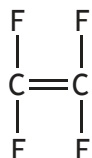

tetrafluoroethene

(i) Name the type of polymerisation used to produce PTFE. 1

(ii) Draw a section of poly(tetrafluoroethene) showing three monomer units joined together. 1

(b) The roof of the O₂ Arena in London is made from a co-polymer. A co-polymer is formed when two different monomers polymerise. The repeating unit of the co-polymer is shown.

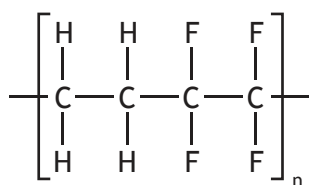

One of the monomers in this co-polymer is tetrafluoroethene. Draw the full structural formula for the other monomer. 1



3. Coal is a fuel that contains carbon. Different types of coal contain different percentages of carbon.

Heat content is a measure of how much heat energy is released when coal is burned.

- (a) The table gives information about types of coal.

<i>Type of coal</i>	<i>Percentage of carbon</i>	<i>Average heat content (kJ kg⁻¹)</i>
Anthracite	86 - 98	32 500
Bituminous	45 - 85	27 850
Sub-bituminous	35 - 44	25 550
Lignite	25 - 34	13 950

Describe how the percentage of carbon in coal affects the average heat content.

1

- (b) Iron pyrite, FeS₂, is an impurity found in coal.
Calculate the percentage of iron in iron pyrite.
Show your working clearly.

3



4. During the FIFA World Cup, referees will spray foam onto the pitch to ensure players stand the correct distance from the ball when a free kick is taken. The foam contains a hydrocarbon mixture of isobutane, butane and propane.

(a) Name the elements present in a hydrocarbon.

1

(b) The full structural formula for isobutane is

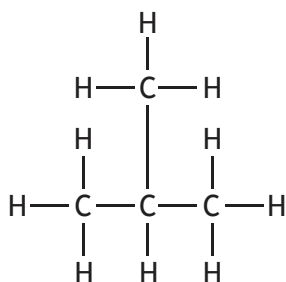

Write the systematic name for isobutane.

1

(c) Alkanes have different physical properties.

The table gives some information about isobutane and butane.

<i>Alkane</i>	<i>Boiling point (°C)</i>
isobutane	-12
butane	-1

Circle the correct words to complete the sentence.

1

Compared to isobutane, butane has a higher boiling point

as it contains $\left\{ \begin{array}{l} \text{weaker} \\ \text{stronger} \end{array} \right\} \left\{ \begin{array}{l} \text{covalent bonds} \\ \text{intermolecular forces} \end{array} \right\}$.



4. (continued)

(d) The table shows the boiling points of some alkanes.

<i>Alkane</i>	<i>Boiling point (°C)</i>
pentane	36
hexane	69
heptane	98
octane	126
nonane	

Predict the boiling point, in °C, of nonane, C₉H₂₀.

1

[Turn over



5. Read the passage and answer the questions that follow.

The Chemistry within Airbags

Airbags, an important safety feature in cars, inflate rapidly on collision. Inside the airbag is a gas generator containing a mixture of sodium azide (NaN_3), potassium nitrate and silicon dioxide.

When a car is involved in a collision, a series of three chemical reactions takes place.

In the first reaction, electrical energy causes sodium azide to decompose producing sodium metal and nitrogen gas. The nitrogen gas that is generated fills the airbag.

In the second reaction, the sodium reacts with potassium nitrate producing more nitrogen gas, sodium oxide and potassium oxide.

In the final reaction, the metal oxides react with silicon dioxide to produce silicate fibres, which are harmless and stable.

This process, from the initial impact of the crash to full inflation of the airbag, takes a fraction of a second.

- (a) Name the three chemicals found inside the gas generator before any chemical reactions take place. 1

- (b) Name the compound produced in the second reaction which would give a lilac flame colour. 1

You may wish to use the data booklet to help you.

- (c) Write the formula for the compound which reacts with the metal oxides in the final reaction. 1



5. (continued)

(d) The graph below gives information on the volume of nitrogen gas produced by the gas generator.

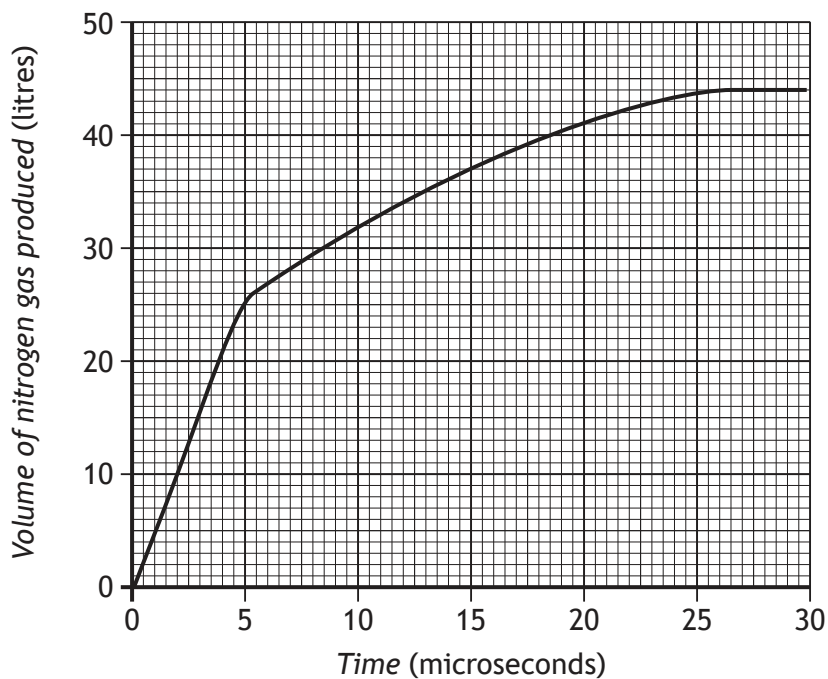

State the total volume, in litres, of nitrogen gas produced.

1

[Turn over



6. Scientists use an instrument called a mass spectrometer to determine the number of isotopes and the percentage of each isotope in a sample of an element.

(a) When a sample of boron is passed through a mass spectrometer the following graph is obtained.

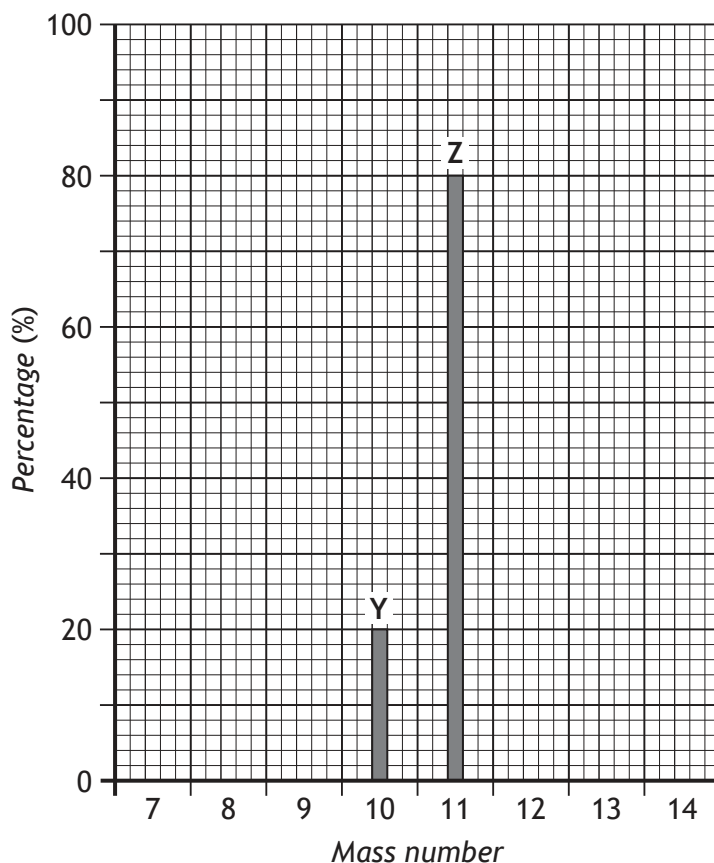

(i) State the number of isotopes present in this sample of boron.

1



6. (a) (continued)

(ii) The relative atomic mass can be calculated using:

$$\frac{(\text{mass of isotope Y} \times \% \text{ of Y}) + (\text{mass of isotope Z} \times \% \text{ of Z})}{100}$$

Using the information from the graph, calculate the relative atomic mass of the sample of boron.

2

Show your working clearly.

(b) Carbon also has more than one isotope.

The nuclide notation for an isotope of carbon can be represented as



Write the nuclide notation for the isotope of carbon with 8 neutrons.

1

[Turn over



7. Strontium chloride, which is an ionic compound, is used in toothpaste to reduce tooth sensitivity.

(a) State the term used to describe the structure of solid strontium chloride. 1

(b) A sample of strontium chloride was electrolysed.

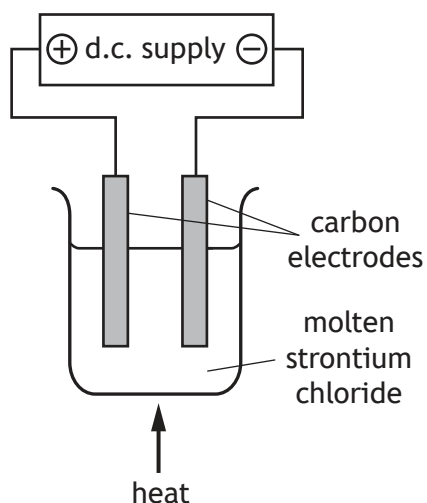

(i) State why ionic compounds, like strontium chloride, conduct electricity when molten. 1

(ii) During electrolysis, chloride ions lose electrons to form chlorine gas.
Name the type of chemical reaction taking place. 1

(iii) Explain why a d.c. supply **must** be used. 1



MARKS

DO NOT
WRITE IN
THIS
MARGIN

8. Water is one of the most versatile of all chemicals and features in many chemical reactions and processes.

Using your knowledge of chemistry, comment on the chemistry of water.

3

[Turn over



* X 8 1 3 7 5 0 1 1 7 *

9. Olive oil, which can be used in cooking, is a mixture of unsaturated molecules.

(a) (i) State what is meant by the term unsaturated.

1

(ii) Describe the chemical test, including the result, that can be used to show that olive oil is unsaturated.

1

(b) When frying food, it is recommended that the oil is heated before food is added.

The table gives information about olive oil used to fry food.

Specific heat capacity of olive oil	1.97 kJ kg ⁻¹ °C ⁻¹
Initial temperature of olive oil	20 °C
Mass of olive oil heated	1500 g

Calculate the energy, in kJ, required to increase the temperature of the olive oil to 180 °C.

3

Show your working clearly



10. Ammonia is made industrially by reacting nitrogen with hydrogen.

(a) The equation for this reaction is

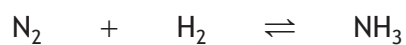

(i) Balance the equation above.

1

(ii) In the equation the symbol \rightleftharpoons is used.

State what this indicates about the reaction.

1

(b) Draw a diagram, showing all outer electrons, to represent a molecule of ammonia, NH_3 .

1

(c) In industry, ammonia can be converted into nitric acid.

Name this industrial process.

1

(d) Ammonia reacts with nitric acid to produce a salt.

Name the salt produced in this reaction.

1



11. A student set up the following cell.

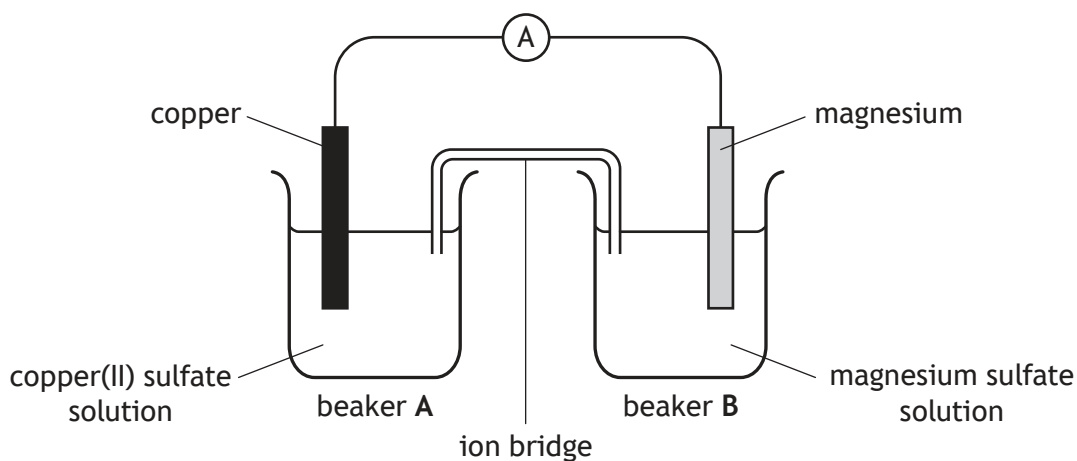

(a) On the diagram, draw an arrow to show the path and direction of electron flow.

1

You may wish to use the data booklet to help you.

(b) Explain why an ion bridge is used to link the beakers.

1

(c) In this reaction, the copper ions are reduced.

Write the ion-electron equation for the reduction of copper(II) ions.

1

You may wish to use the data booklet to help you.



* X 8 1 3 7 5 0 1 2 0 *

MARKS

DO NOT
WRITE IN
THIS
MARGIN

11. (continued)

(d) Other magnesium compounds could be used in place of magnesium sulfate when making this type of cell.

Suggest why magnesium phosphate would **not** be suitable.

1

You may wish to use the data booklet to help you.

[Turn over



* X 8 1 3 7 5 0 1 2 1 *

12. Thallium-204 decays by emitting beta particles and can be used in industry to measure the thickness of paper.

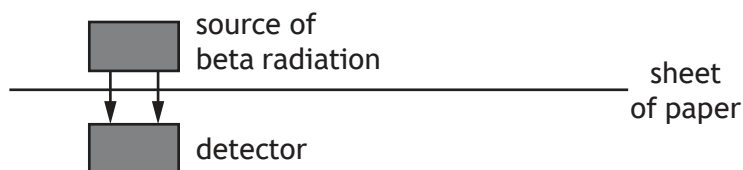

- (a) Suggest a reason why a radioisotope which emits alpha particles is not suitable for this purpose.

1

- (b) A paper manufacturer found a thallium-204 source had only $\frac{1}{16}$ of its original activity.

The half-life of thallium-204 is 3.7 years.

Calculate the age, in years, of the source.

2

Show your working clearly.

- (c) Circle the correct words to complete the sentence.

1

When an atom emits a beta particle,

the atomic number of the atom $\left\{ \begin{array}{l} \text{increases} \\ \text{decreases} \\ \text{stays the same} \end{array} \right\}$ and

the mass number $\left\{ \begin{array}{l} \text{increases} \\ \text{decreases} \\ \text{stays the same} \end{array} \right\}$.



13. Malic acid is a carboxylic acid found in some fruits.

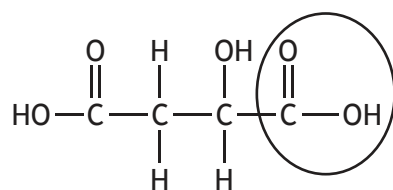

- (a) (i) Name the functional group circled in the diagram above. 1
- (ii) Calculate the mass, in grams, of 1 mole of malic acid. 1

[Turn over



13. (continued)

(b) Carboxylic acids can contain a halogen atom. The pH of 1 mol⁻¹ solutions of some of these acids are given in the table.

<i>Carboxylic acid</i>	<i>pH</i>
$\begin{array}{c} \text{H} \quad \text{O} \\ \quad \\ \text{Br}-\text{C}-\text{C}-\text{OH} \\ \\ \text{H} \end{array}$	1.45
$\begin{array}{c} \text{H} \quad \text{O} \\ \quad \\ \text{Cl}-\text{C}-\text{C}-\text{OH} \\ \\ \text{H} \end{array}$	1.42
$\begin{array}{c} \text{H} \quad \text{O} \\ \quad \\ \text{F}-\text{C}-\text{C}-\text{OH} \\ \\ \text{H} \end{array}$	1.33
$\begin{array}{c} \text{H} \quad \text{O} \\ \quad \\ \text{I}-\text{C}-\text{C}-\text{OH} \\ \\ \text{H} \end{array}$	1.55

Describe how the acidity of the carboxylic acid is related to the position of the halogen in group 7 of the periodic table.

1



13. (continued)

- (c) The Jones oxidation reaction can be used to convert alcohols to carboxylic acids.

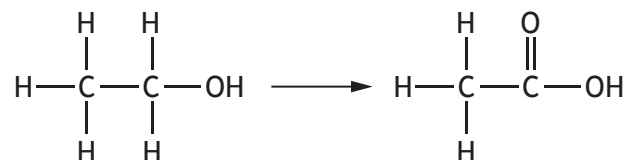

The following alcohol can also be converted to a carboxylic acid by the Jones oxidation reaction.

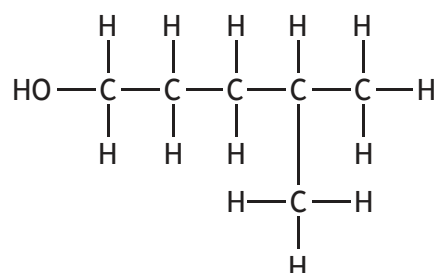

Draw a structural formula for the carboxylic acid produced in this reaction.

1

[Turn over



14. Chloride ion concentrations greater than 0.25 g l^{-1} can cause a noticeable taste in drinking water.

The table gives information about the chloride ion concentration in drinking water from different sources.

Source	Chloride ion concentration (g l^{-1})
A	0.26
B	0.28
C	0.24

- (a) One of the sources provides drinking water that does **not** have a noticeable taste.

Identify this source.

1

- (b) A student investigated the concentration of chloride ions in drinking water from another source.

Samples of water were titrated with silver nitrate solution.

An indicator was used to show when the end-point was reached.

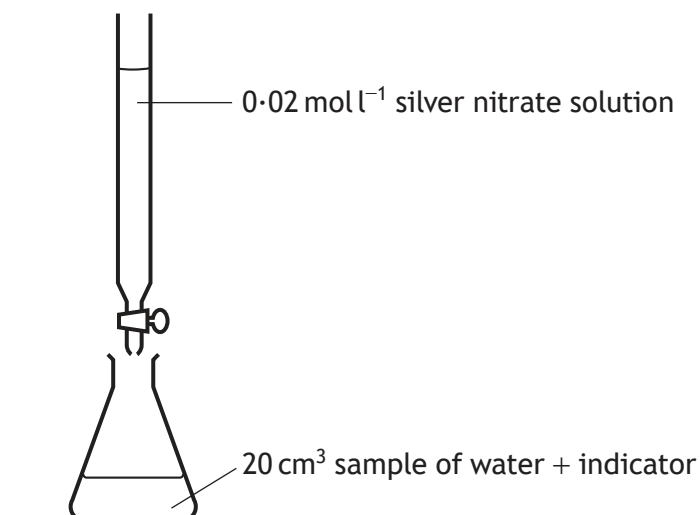

Titration	Volume of silver nitrate added (cm^3)
1	9.6
2	8.0
3	8.5
4	8.1



14. (b) (continued)

(i) Name the most appropriate piece of apparatus to measure 20 cm³ samples of water into the flask. 1

(ii) The average volume of silver nitrate that should be used to calculate the chloride ion concentration is 8.05 cm³.
Explain why only the results of titration 2 and titration 4 are used to calculate this average. 1

(iii) Calculate the number of moles of silver nitrate in 8.05 cm³. 1
Show your working clearly.

[Turn over



15. Read the passage and answer the questions that follow.

The bizarre world of high pressure chemistry

What would happen if you put some sodium, normally a soft grey metal, under extremely high pressure?

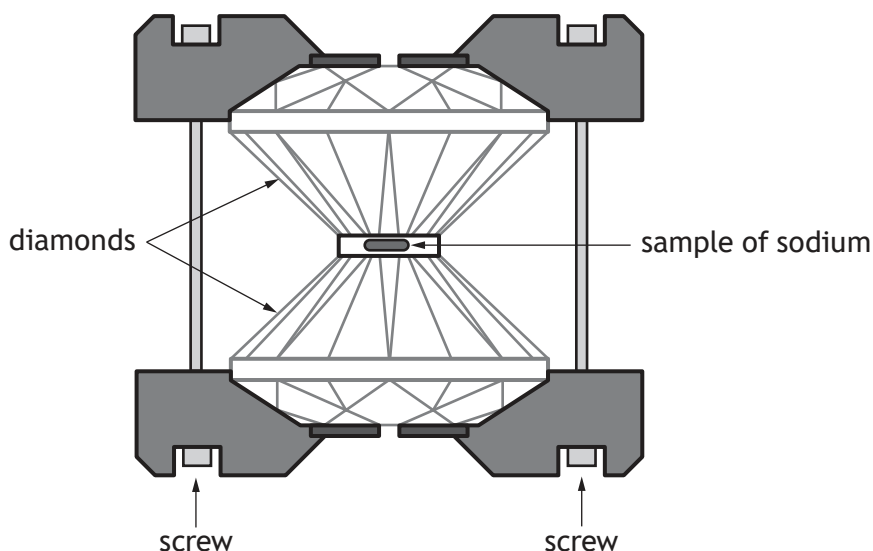

Researchers investigated this using a piece of apparatus called a diamond anvil cell. The diamond anvil cell contains two diamonds and as the screws are tightened, high pressure is created. The pressure between the diamonds can reach 1000 gigapascals, which is a pressure of 10 million atmospheres.

When sodium is squeezed to 190 gigapascals it loses an important property of metals and becomes an insulator. This shows that there is a change in the structure and bonding of sodium.

The diamond anvil cell also allows scientists to create new materials, including superconductors.

Scientists are studying what happens to the materials thought to be deep inside the Earth, where high pressure occurs naturally.

Using this technique to mirror what may happen to materials deep in the Earth, iron(III) oxide is found to decompose, releasing oxygen, and forming the very unusual Fe_5O_7 .

Adapted from *The Catalyst*, Volume 27, Number 1, October 2016



15. (continued)

(a) Name the piece of apparatus used by researchers to create high pressure.

1

(b) (i) Calculate the pressure, in atmospheres, when sodium is squeezed at 190 gigapascals.

1

(ii) Suggest what would be observed if this pressurised sodium was placed in the circuit below.

1

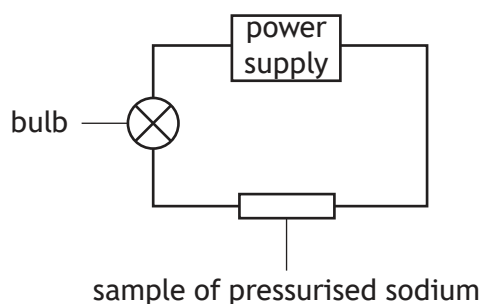

(c) Write an equation, using symbols and formulae, to show the decomposition of iron(III) oxide, at high pressure.

1

There is no need to balance this equation.



16. The thiols are a family of compounds containing carbon, hydrogen and sulfur.

Name	Full structural formula
methanethiol	<pre> H H — C — S \ H H </pre>
ethanethiol	<pre> H H H — C — C — S \ H H H </pre>
propanethiol	<pre> H H H H — C — C — C — S \ H H H H </pre>

(a) Thiols have the same general formula and similar chemical properties.

(i) State the term used to describe a family of compounds such as the thiols. 1

(ii) Suggest a general formula for this family. 1

(b) Ethanethiol can react with oxygen as shown.

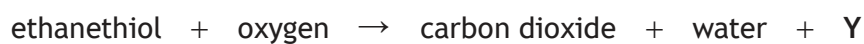

Identify Y. 1



16. (continued)

- (c) Methanethiol, which smells like rotting cabbage, is added to natural gas to allow gas leaks to be detected.

It is prepared industrially by the reaction of methanol with hydrogen sulfide gas.



Calculate the mass of methanethiol, in grams, produced when 640 grams of methanol reacts completely with hydrogen sulfide.

3

Show your working clearly.



* X 8 1 3 7 5 0 1 3 1 *

17. Methacrylic acid is used to make methacrylates which are used in Shellac nail polish.

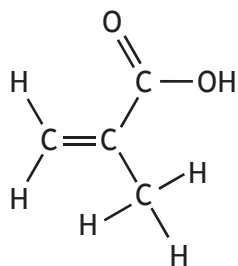

methacrylic acid

Using your knowledge of chemistry, comment on the chemistry of methacrylic acid.

3

[END OF QUESTION PAPER]



MARKS

DO NOT
WRITE IN
THIS
MARGIN

ADDITIONAL SPACE FOR ANSWERS AND ROUGH WORKING

Additional graph paper for Question 1 (b) (ii)

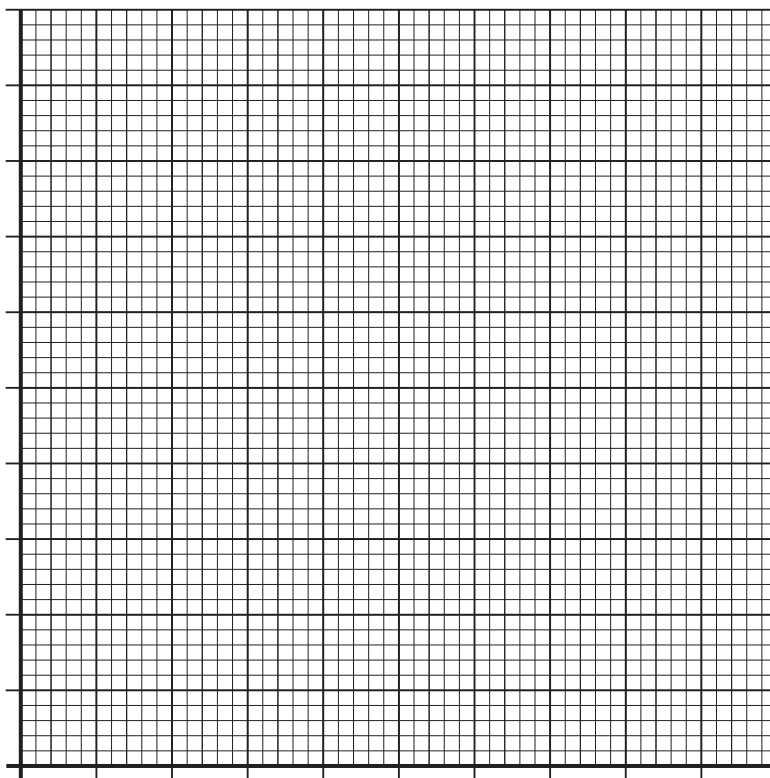

* X 8 1 3 7 5 0 1 3 3 *

MARKS

DO NOT
WRITE IN
THIS
MARGIN

ADDITIONAL SPACE FOR ANSWERS AND ROUGH WORKING



* X 8 1 3 7 5 0 1 3 4 *

MARKS

DO NOT
WRITE IN
THIS
MARGIN

ADDITIONAL SPACE FOR ANSWERS AND ROUGH WORKING



* X 8 1 3 7 5 0 1 3 5 *

ACKNOWLEDGEMENTS

Question 15 – Article and diagram are adapted from “The Bizarre world of high pressure chemistry” by Vicky Wong, taken from *The Catalyst*, Volume 27, Issue 1, October 2016.

SQA has made every effort to trace the owners of copyright materials in this question paper, and seek permissions. We will be happy to incorporate any missing acknowledgements. Please contact question.papers@sqa.org.uk.



* X 8 1 3 7 5 0 1 3 6 *