



National
Qualifications
2024

X813/75/02

**Chemistry
Section 1 — Questions**

THURSDAY, 23 MAY

1:00 PM – 3:30 PM

Instructions for the completion of Section 1 are given on *page 02* of your question and answer booklet X813/75/01.

Record your answers on the answer grid on *page 03* of your question and answer booklet.

You may refer to the Chemistry Data Booklet for National 5.

Before leaving the examination room you must give your question and answer booklet to the Invigilator; if you do not, you may lose all the marks for this paper.



* X 8 1 3 7 5 0 2 *

SECTION 1 — 25 marks

Attempt ALL questions

1. An experiment was carried out to investigate the rate of a reaction.

In the first 5 minutes the pressure decreased by 0.6 bar.

The unit for the average rate of this reaction is

- A bar/min⁻¹
B bar min⁻¹
C min/bar
D min bar⁻¹
2. Which two lines in the table show particles that are isotopes of the same element?

Particle	Number of protons	Number of neutrons	Number of electrons
W	11	12	10
X	11	12	11
Y	12	12	12
Z	12	14	12

- A W and X
B X and Z
C W and Y
D Y and Z
3. An atom of tin has 74 neutrons.
Which of the following is the mass number of this atom?
You may wish to use the data booklet to help you.
- A 50
B 74
C 118.5
D 124

4. Lead forms many compounds with non-metal elements.

At room temperature tetraethylplumbane, $\text{Pb}(\text{C}_2\text{H}_5)_4$, is a liquid that does not conduct electricity and is insoluble in water.

The structure and bonding in tetraethylplumbane is

- A covalent molecular
B covalent network
C ionic lattice
D metallic lattice.
5. Hydrogen bonds are a type of intermolecular force that exists between some molecules.
Hydrogen bonds will exist between molecules that contain a hydrogen atom **directly bonded** to an atom of either nitrogen, oxygen or fluorine.

Which of the following substances will have hydrogen bonds between its molecules?

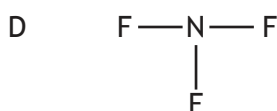
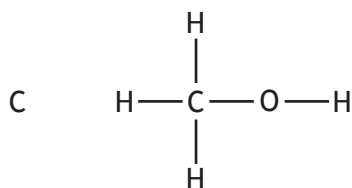
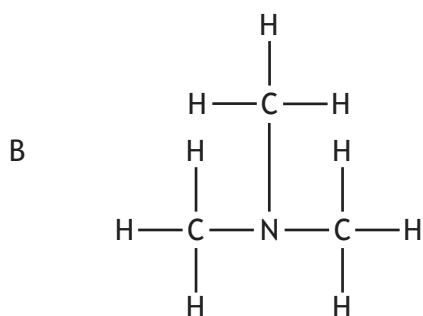
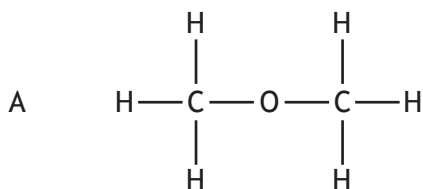

[Turn over

6. Which of the following compounds, when added to water, will change its pH?

You may wish to use the data booklet to help you.

- A Aluminium oxide
- B Calcium oxide
- C Copper(II) oxide
- D Zinc(II) oxide

7.



How many moles of oxygen would be needed to react completely with 4 moles of magnesium?

- A 1
- B 2
- C 4
- D 8

8. Which of the following elements has the lowest gram formula mass?

- A Nitrogen
- B Oxygen
- C Fluorine
- D Neon

9. 25 cm³ of water was added to an aqueous solution of sodium hydroxide.

Compared to the initial sodium hydroxide solution, the final sodium hydroxide solution has

- A a lower number of moles of sodium hydroxide and a higher pH
- B the same number of moles of sodium hydroxide and a higher pH
- C the same number of moles of sodium hydroxide and a lower pH
- D a lower number of moles of sodium hydroxide and a lower pH.

10. Which of the following is most likely to be a use for alkanes?

- A Fuels
- B Soaps
- C Medicines
- D Flavourings

11. The table shows three members of the cycloalkyne family.

Name	Molecular formula
Cyclooctyne	C_8H_{12}
Cyclononyne	C_9H_{14}
Cyclodecyne	$C_{10}H_{16}$

Which of the following is the general formula for the cycloalkyne family?

- A C_nH_{2n}
- B C_nH_{2n-2}
- C C_nH_{2n-4}
- D C_nH_{2n-6}

12. Which of the following compounds is an isomer of pent-2-ene?

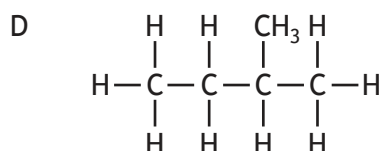
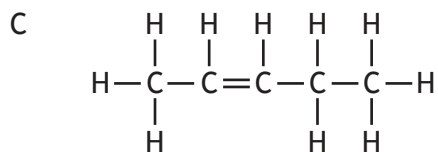
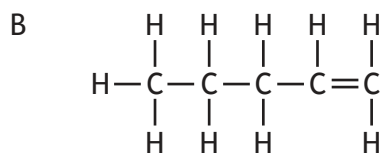
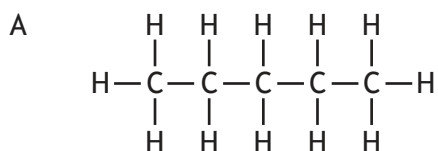

[Turn over

13.

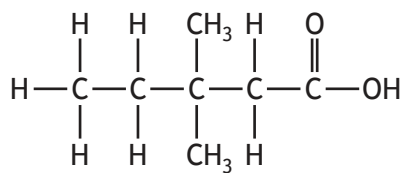

The shortened structural formula for this compound is

- A $\text{CH}_3\text{CH}_2\text{CH}(\text{C}_2\text{H}_5)\text{CH}_2\text{COOH}$
- B $\text{CH}_3\text{CH}_2\text{C}(\text{CH}_3)_2\text{CH}_2\text{COOH}$
- C $\text{CH}_3\text{CH}(\text{C}_2\text{H}_5)\text{CH}_2\text{CH}_2\text{COOH}$
- D $\text{CH}_3\text{C}(\text{CH}_3)_2\text{CH}_2\text{CH}_2\text{COOH}$

14. Which bond do ethane, ethene, ethanol and ethanoic acid **all** contain?

- A C—C
- B C—O
- C C—H
- D O—H

15. The table shows how the number of carbon atoms bonded to the nitrogen atom determines the classification of an amine.

Number of carbon atoms bonded to the nitrogen atom	Example	Amine classification
1	$\begin{array}{c} \text{H} \\ \\ \text{N}-\text{CH}_3 \\ \\ \text{H} \end{array}$	primary
2	$\begin{array}{c} \text{H}_3\text{C} \\ \\ \text{N}-\text{CH}_3 \\ \\ \text{H} \end{array}$	secondary
3	$\begin{array}{c} \text{H}_3\text{C} \\ \\ \text{N}-\text{CH}_3 \\ \\ \text{H}_3\text{C} \end{array}$	tertiary

Which of the following is a secondary amine?

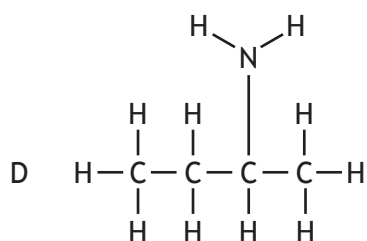
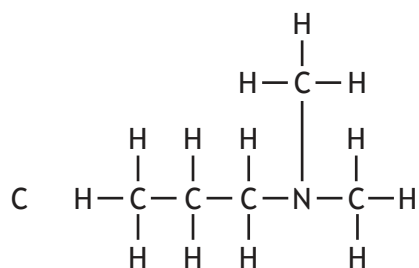
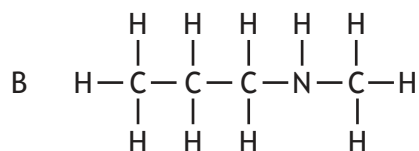
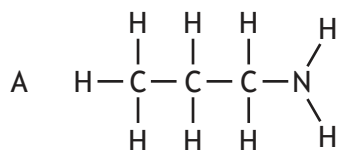

Questions 16 and 17 refer to the experiment below.

The apparatus shown was used to measure the energy released when four different fuels were burned.

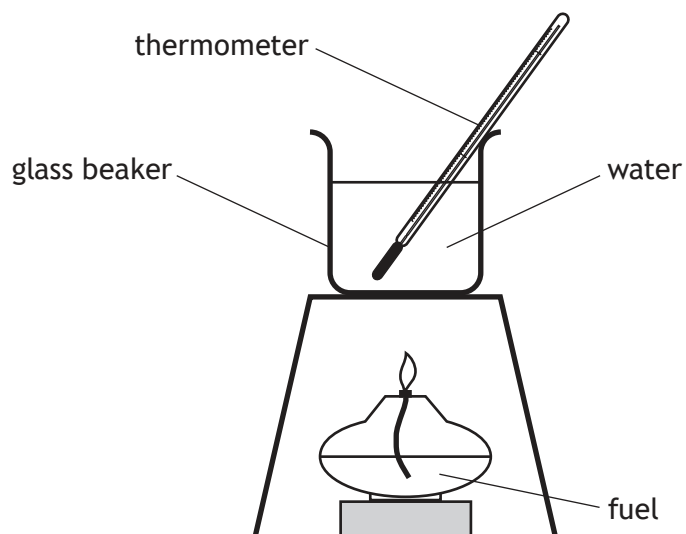

16. In which experiment was the most energy released?

	Mass of water (kg)	Temperature rise (°C)
A	0.05	10
B	0.05	20
C	0.25	8
D	0.25	18

17. Which of the following changes would **not** improve the experimental results?

- A Increasing the distance between the burner and the beaker
- B Placing a lid on the beaker
- C Using a copper beaker
- D Using a heat shield/draft shield

18. Which of the following substances in the table below would have the following structure?

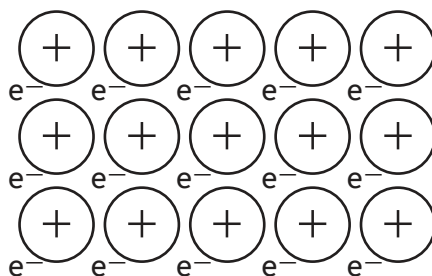

Substance	Melting point (°C)	Boiling point (°C)	Conducts electricity	
			Solid	Liquid
A	30	2229	yes	yes
B	-118	90	no	no
C	714	1412	no	yes
D	2077	4000	no	no

19. When magnesium reacts with dilute hydrochloric acid, magnesium chloride is formed. Name the other substance formed.

- A Hydrogen chloride
- B Hydrogen
- C Chlorine
- D Water

20. The ion electron equations for the reactions taking place during the electrolysis of aluminium oxide are given below.

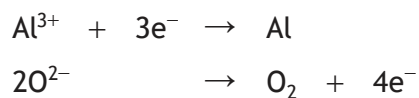

The redox equation for the overall reaction is

- A $4\text{Al}^{3+} + 6\text{O}^{2-} \rightarrow 4\text{Al} + 3\text{O}_2$
- B $3\text{Al}^{3+} + 3\text{O}^{2-} \rightarrow 3\text{Al} + 3\text{O}_2$
- C $\text{Al}^{3+} + 2\text{O}^{2-} \rightarrow \text{Al} + \text{O}_2 + \text{e}^{-}$
- D $\text{Al}^{3+} + 2\text{O}^{2-} + 3\text{e}^{-} \rightarrow \text{Al} + \text{O}_2 + 4\text{e}^{-}$

[Turn over

21. Which of the following statements is true for ammonia?
- A It has the formula NH_4^+ .
 - B It will react with acids.
 - C It will turn damp pH paper red.
 - D It is a solid at room temperature.
22. Which of the following compounds can be used to provide two of the essential elements required for healthy plant growth?
- A K_2CO_3
 - B K_2SO_4
 - C NH_4NO_3
 - D $(\text{NH}_4)_3\text{PO}_4$
23. Which metal is used as the catalyst in the industrial manufacture of ammonia?
- A Platinum
 - B Nickel
 - C Iron
 - D Palladium
24. ${}^{228}_{88}\text{Ra} \xrightarrow{\beta \text{ emission}} \text{Q} \xrightarrow{\beta \text{ emission}} \text{R} \xrightarrow{\alpha \text{ emission}} \text{S}$

Identify the radioisotope, S, that is formed when radium-228 decays by emission of two beta particles and an alpha particle.

- A ${}^{220}_{83}\text{Bi}$
- B ${}^{220}_{85}\text{At}$
- C ${}^{224}_{86}\text{Rn}$
- D ${}^{224}_{88}\text{Ra}$

25. The table shows the colours of ions in solution.

Ion	Colour in solution
Sodium	colourless
Calcium	colourless
Copper(II)	blue
Chloride	colourless
Chromate	yellow
Dichromate	orange

Which line in the table is correct for the colour in solution and the flame colour when copper(II) chloride is burned?

You may wish to use the data booklet to help you.

	Colour in solution	Flame colour
A	colourless	blue
B	blue-green	blue
C	colourless	blue-green
D	blue	blue-green

[END OF SECTION 1. NOW ATTEMPT THE QUESTIONS IN SECTION 2 OF YOUR QUESTION AND ANSWER BOOKLET]

FOR OFFICIAL USE



National
Qualifications
2024

Mark

X813/75/01

**Chemistry
Section 1 — Answer grid
and Section 2**

THURSDAY, 23 MAY

1:00 PM – 3:30 PM



* X 8 1 3 7 5 0 1 *

Fill in these boxes and read what is printed below.

Full name of centre

Town

Forename(s)

Surname

Number of seat

Date of birth

Day

Month

Year

Scottish candidate number

Total marks — 100

SECTION 1 — 25 marks

Attempt ALL questions.

Instructions for the completion of Section 1 are given on *page 02*.

SECTION 2 — 75 marks

Attempt ALL questions.

You may refer to the Chemistry Data Booklet for National 5.

Write your answers clearly in the spaces provided in this booklet. Additional space for answers and rough work is provided at the end of this booklet. If you use this space you must clearly identify the question number you are attempting. Any rough work must be written in this booklet. You should score through your rough work when you have written your final copy.

Use **blue** or **black** ink.

Before leaving the examination room you must give this booklet to the Invigilator; if you do not, you may lose all the marks for this paper.



* X 8 1 3 7 5 0 1 0 1 *

SECTION 2 — 75 marks

Attempt ALL questions

1. A decomposition reaction occurs when one reactant breaks down to form two or more products.

(a) The equation for the decomposition of hydrogen peroxide is shown.



- (i) Balance the above equation.

1

- (ii) The rate of this reaction can be increased by the addition of manganese(IV) oxide.

The manganese(IV) oxide can be recovered unchanged at the end of the reaction.

State the role of manganese(IV) oxide in this reaction.

1

[Turn over



* X 8 1 3 7 5 0 1 0 5 *

1. (a) (continued)

- (iii) A student was asked to calculate the average rate of reaction for the decomposition of hydrogen peroxide using manganese(IV) oxide. The equipment shown was used to collect and measure the volume of gas produced.

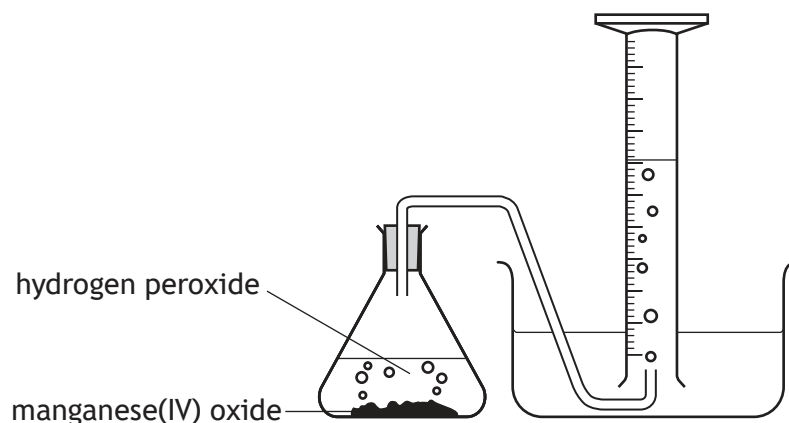

- (A) State the property of oxygen gas that allows it to be collected by this method. 1
- (B) The student calculated the average rate of reaction to be $1.2 \text{ cm}^3 \text{ s}^{-1}$ for the first 30 seconds of the reaction. Calculate the volume of gas, in cm^3 , collected in the measuring cylinder after 30 seconds. 2
- (C) Predict the average rate of reaction, in $\text{cm}^3 \text{ s}^{-1}$, for this experiment between 60 and 90 seconds. 1



1. (continued)

- (b) Sodium hydrogencarbonate, NaHCO_3 , decomposes when heated above $80\text{ }^\circ\text{C}$. The equation for this reaction is

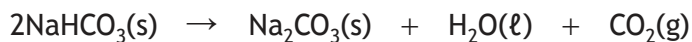

A teacher set up the following experiment to demonstrate the reaction to a class.

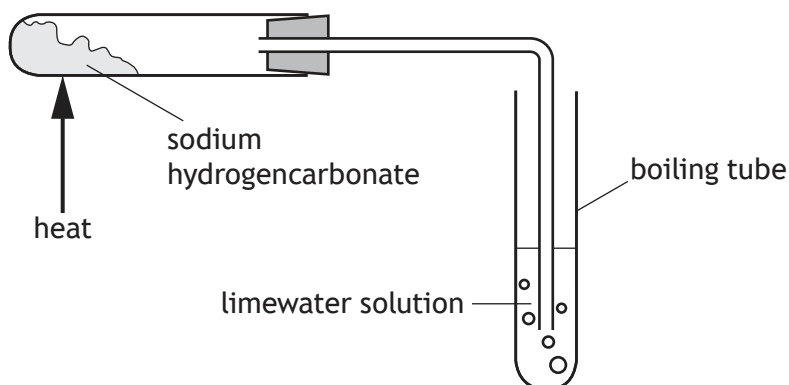

- (i) Describe the change that would be observed as the gas produced is bubbled through the solution in the boiling tube. 1
- (ii) Sodium hydrogencarbonate can also react with citric acid in a chemical reaction that takes in heat energy. State the term used to describe all chemical reactions that take in heat energy. 1

[Turn over



2. Ammonia, NH_3 , is a widely used compound.

(a) (i) State the term used to describe the shape of the ammonia molecule.

1

(ii) Draw a diagram, showing **all** outer electrons, to represent a molecule of ammonia, NH_3 .

1

(b) Ammonia is a reactant in the Ostwald process.

Name the product made by the Ostwald process.

1



2. (continued)

- (c) Ammonia is a greenhouse gas that is released from animal waste and fertilisers.

The table shows some sources of ammonia.

Source of ammonia	Percentage (%)
Poultry	15
Fertiliser use	23
Beef cattle	20
Dairy cattle	28
Other	14

Draw a graph showing the information in the table.

4

(Additional graph paper, if required, can be found on page 32.)

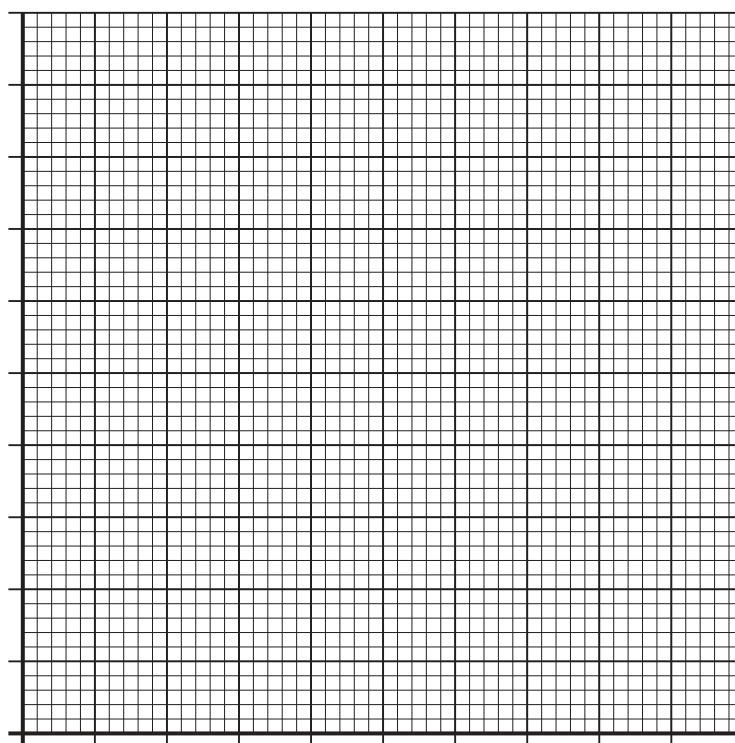

[Turn over



2. (continued)

(d) Ammonia can also be used to make the fertiliser urea, as shown in the flow diagram below.

On the flow diagram, draw an arrow to show how the process could be made more economical.

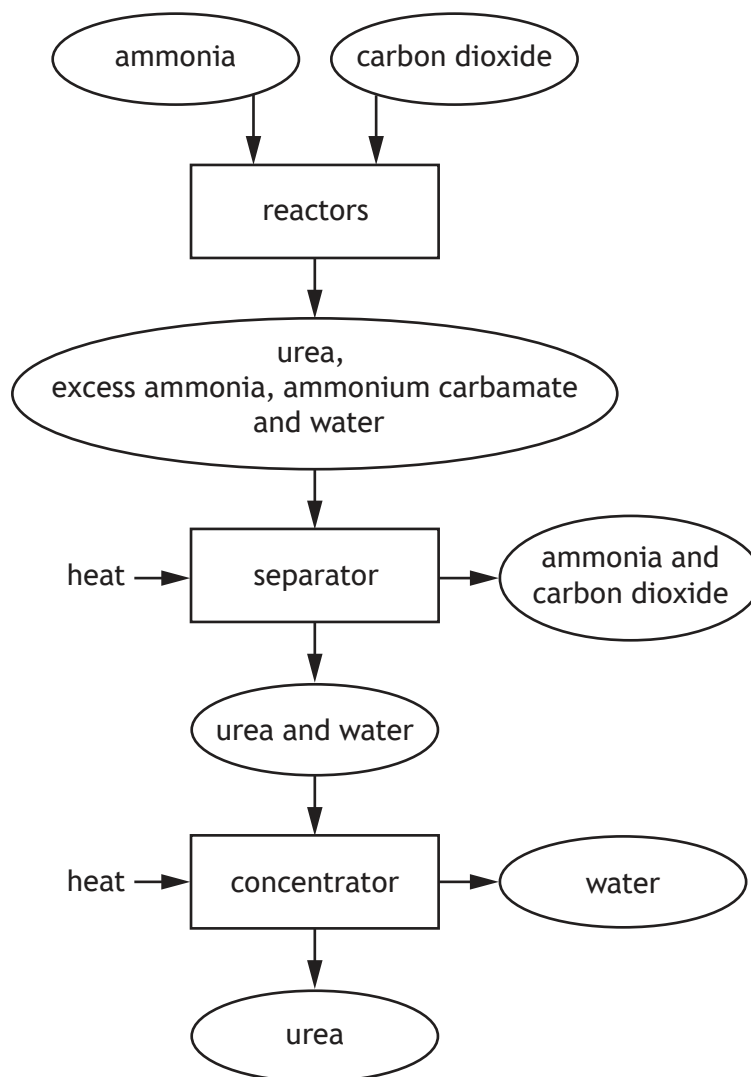

3. Read the passage and answer the questions that follow.

Lavender oils

There are many types of lavender oil that can be extracted from lavender plants. These oils are known as essential oils.

Lavender flower oil is colourless and insoluble in water. It has a density of 0.885 g cm^{-3} and a boiling point of $204 \text{ }^\circ\text{C}$. It smells sweet and is used in perfume.

Lavender spike oil is pale yellow and soluble in water. It has a density of 0.905 g cm^{-3} and a boiling point of $183 \text{ }^\circ\text{C}$. It has a sharp smell and is used as a solvent for paints.

Essential oils are complex mixtures of chemicals. The structures of three chemicals found in lavender oils are shown with their boiling point, density and gram formula mass, *GFM*.

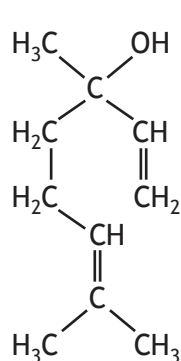

linalool
 $198 \text{ }^\circ\text{C}$
 0.900 g cm^{-3}
GFM = 154

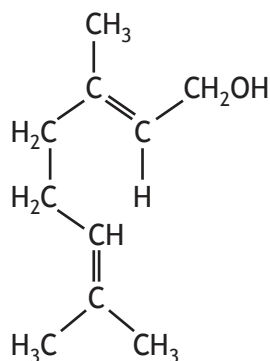

geraniol
 $230 \text{ }^\circ\text{C}$
 0.889 g cm^{-3}
GFM = 154

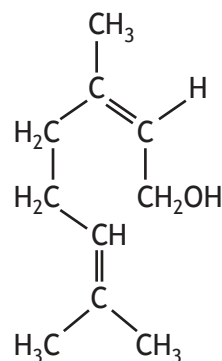

nerol
 $225 \text{ }^\circ\text{C}$
 0.881 g cm^{-3}
GFM = 154

(a) State the term used to describe oils such as lavender oil.

1

(b) Complete the table for the two types of lavender oil.

2

	Lavender flower oil	Lavender spike oil
Density (g cm^{-3})		
Boiling point ($^\circ\text{C}$)		



3. (continued)

(c) State the type of lavender oil that could be sold as an aqueous solution. 1

(d) Describe the chemical test, including the result, to show that linalool, geraniol and nerol are all unsaturated. 1

(e) Explain why geraniol has a higher boiling point than linalool and nerol. 2

(f) The relationship used to calculate mass from density and volume is

$$\text{mass (g)} = \text{density (g cm}^{-3}\text{)} \times \text{volume (cm}^3\text{)}$$

Calculate the mass, in grams, of 3 cm³ of nerol. 2

Show your working clearly.

[Turn over



4. Alcohols are a family of compounds.

(a) State the term used to describe a family of compounds that share a general formula and have similar chemical properties.

1

(b) The boiling points of some alcohols are given in the table.

Name	Boiling point (°C)
Methanol	65
Ethanol	78
Propan-1-ol	97
Butan-1-ol	118
Pentan-1-ol	

(i) Predict the boiling point, in °C, for pentan-1-ol.

1

(ii) Describe the relationship shown by the data in the table.

1



* X 8 1 3 7 5 0 1 1 4 *

4. (continued)

(c) Alcohols can react with acidified potassium dichromate to form carboxylic acids.

(i) Circle the correct words to complete the sentence.

When alcohols react with acidified potassium dichromate the functional group changes from $\left\{ \begin{array}{l} \text{hydroxyl} \\ \text{carboxyl} \end{array} \right\}$ to $\left\{ \begin{array}{l} \text{hydroxyl} \\ \text{carboxyl} \end{array} \right\}$.

1

(ii) An example of this type of reaction is shown.

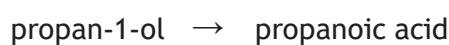

Draw a structure for the carboxylic acid produced when butan-1-ol reacts with acidified potassium dichromate.

1

(iii) Write the formula for potassium dichromate, showing the charge on both ions.

1

You may wish to use the data booklet to help you.

[Turn over



5. Dmitri Mendeleev produced a Periodic Table of the Elements in 1869.

Using your knowledge of chemistry, comment on how the elements are positioned in the Periodic Table.

3



* X 8 1 3 7 5 0 1 1 6 *

6. Copper is a metal found in the Periodic Table.

(a) State why the bonding in metal elements, like copper, allows them to conduct electricity.

1

(b) Suggest how copper can be extracted from its ore.

1

[Turn over



6. (continued)

- (c) The apparatus shown can be used to investigate the size of the voltage produced when copper is paired with different metals in a cell.

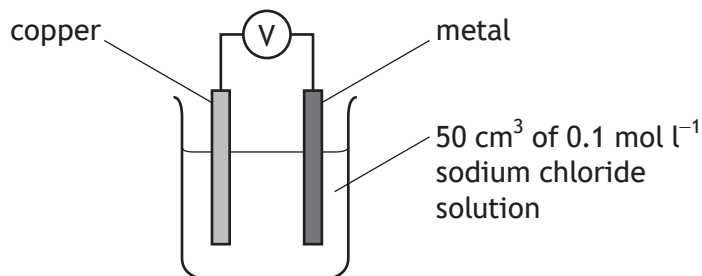

The size of the voltage and the direction of electron flow when copper is paired with four different metals is shown in the table.

Metal	Voltage (V)	Direction of electron flow
A	0.6	metal A → copper
B	0.2	copper → metal B
C	0.9	metal C → copper
D	0.1	copper → metal D

- (i) Using the information in the table arrange **copper** and the metals **A, B, C, D** into an electrochemical series.

(An additional table, if required, can be found on *page 32.*)

2

Order in the electrochemical series	Metal
highest	
↓	
↓	
↓	
↓	
lowest	

6. (c) (continued)

- (ii) Explain why glucose solution, $C_6H_{12}O_6$, **cannot** be used instead of sodium chloride solution in the cell.

1

- (d) Another way of producing a voltage is to use two half-cells as shown.

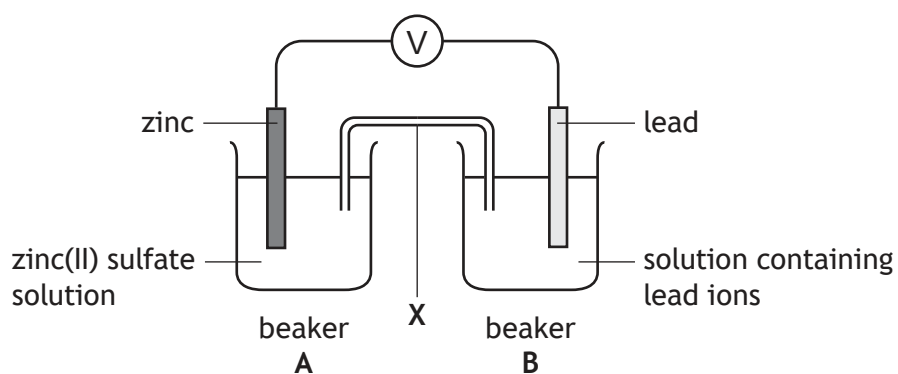

- (i) Name the piece of apparatus labelled X.

1

- (ii) Suggest a name for a suitable compound that could be used in beaker B. You may wish to use the data booklet to help you.

1

[Turn over



7. Read the passage and answer the questions that follow.

Cleaning water — from ground to tap

Water needs to be cleaned before it is safe for drinking. One of the chemicals used to clean water is ozone, O_3 , because it kills bacteria and viruses present in the water.

The machine used to produce the ozone operates at a very high voltage and contains multiple electrodes, which produce controlled lightning. This lightning turns oxygen, O_2 , into ozone, O_3 .

The ozone is added to the water in a tank where it takes around seven minutes to clean the water. Excess ozone is converted back to oxygen, using heat, to prevent it being released into the atmosphere. Ozone is also removed from the water by adding the chemical sodium hydrogensulfite.

One of the final stages in cleaning water is the addition of chlorine to prevent the growth of disease-causing viruses and bacteria. When chlorine is added to water, hypochlorous acid, $HOCl$, and hydrochloric acid, HCl , are formed.

(a) State why ozone is used to clean water. 1

(b) Name the elements found in the chemical added to remove ozone. 1

(c) Write an equation, using symbols and formulae, to show the reaction that prevents the growth of disease-causing viruses and bacteria. 1

There is no need to balance this equation.



7. (continued)

(d) Alkenes react with ozone, O₃, to make two products as shown.

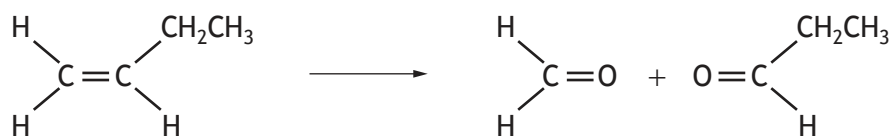

Draw **both** of the products formed from the reaction of the following alkene.

1

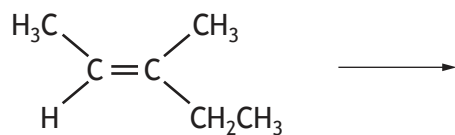

[Turn over



8. A primary standard is a chemical that can be used to make a standard solution. Standard solutions can be used to find the concentration of other chemicals.

(a) Silver nitrate is a primary standard that is used to find the concentration of chloride ions in a sodium chloride solution.

An equation for the reaction of silver nitrate and sodium chloride is shown.

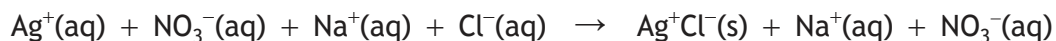

(i) Write the equation with the spectator ions removed.

1

(ii) State the type of chemical reaction that takes place between silver nitrate solution and sodium chloride solution.

1

(b) Oxalic acid, $\text{H}_2\text{C}_2\text{O}_4$, is another primary standard. It can be used to determine the concentration of a sodium hydroxide solution in a titration.

The results of a titration experiment are shown.

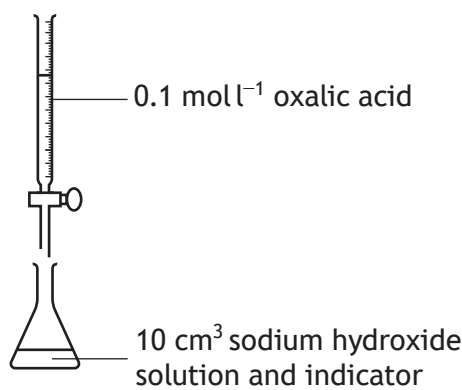

	1 st titre	2 nd titre	3 rd titre
Initial burette reading (cm ³)	0.0	16.4	31.9
Final burette reading (cm ³)	16.4	31.9	47.6
Volume used (cm ³)	16.4	15.5	15.7

(i) Name the most appropriate piece of apparatus to measure the 10 cm³ of sodium hydroxide solution.

1

(ii) The average volume of oxalic acid that should be used to calculate the sodium hydroxide concentration is 15.6 cm³.

Explain why only the results of 2nd and 3rd titre are used to calculate this average.

1



8. (b) (continued)

MARKS DO NOT WRITE IN THIS MARGIN

(iii) The equation for the reaction is

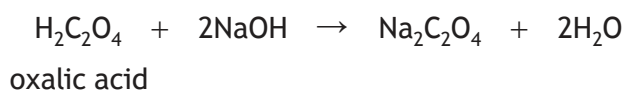

Using the average volume of oxalic acid as 15.6 cm³, calculate the concentration, in mol l⁻¹, of the sodium hydroxide solution.

3

Show your working clearly.

(iv) The indicator used in this titration is called phenolphthalein.

The table below shows some information about the colour of phenolphthalein in different conditions.

Phenolphthalein indicator		
Colour in acidic solutions	Colour in neutral solutions	Colour in alkaline solutions
colourless	colourless	pink

State the colour change, including **initial and final** colour, that indicates the end point of the titration.

1

[Turn over



9. A student carried out an experiment to prepare nickel(II) sulfate crystals.
- (a) The first step in the experiment was to prepare a nickel(II) sulfate solution by completely neutralising 25 cm³ of sulfuric acid. This was done by adding an excess of nickel(II) carbonate powder. A gas was also produced.
- (i) Suggest how the student would know when the acid was completely neutralised. 1
- (ii) Name the compound that is produced in all neutralisation reactions. 1
- (iii) State the term used to describe a substance, such as nickel(II) carbonate, that neutralises an acid. 1
- (iv) The sulfuric acid used had a concentration of 1 mol l⁻¹.
Calculate the number of moles in 25 cm³ of sulfuric acid with a concentration of 1 mol l⁻¹. 1
- (b) The second step in the experiment was to remove excess nickel(II) carbonate from the nickel(II) sulfate solution.
Name this experimental technique. 1



9. (continued)

- (c) The final step in the experiment was to leave the nickel(II) sulfate solution for a few days to evaporate, leaving solid nickel(II) sulfate crystals.

Suggest how the student could have carried out this step in a much shorter time.

1

- (d) Calculate the percentage by mass of nickel in nickel(II) sulfate, NiSO_4 .

Show your working clearly.

3

[Turn over



* X 8 1 3 7 5 0 1 2 5 *

10. Alkanes, alkenes and cycloalkanes are all families of hydrocarbons.

(a) State what is meant by the term hydrocarbon.

(b) The energy released when a hydrocarbon is burned can be calculated by working out the difference between the total energy needed when all of the bonds in the reactants are **broken** and the total energy released when all of the bonds in the products are **made**.

The burning of methane can be represented by the following equation.

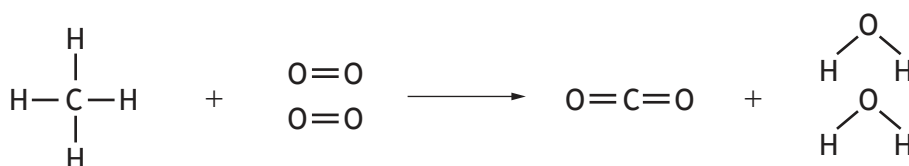

bonds being **broken** in the reactants bonds being **made** in the products

The total energy needed for all of the bonds in the reactants to be **broken** is calculated as shown.

Bond	Bond energy (kJ)	Number of bonds broken	Total energy needed (kJ)
C-H	412	4	4 × 412 = 1648
O=O	498	2	2 × 498 = 996
Total energy to break all the bonds in the reactants =			1648 + 996 = 2644

10. (b) (continued)

- (i) Complete the table below to calculate the total energy released when all of the bonds in the products are **made**.

2

(An additional table, if required, can be found on *page 33*.)

Bond	Bond energy (kJ)	Number of bonds made	Total energy released (kJ)
C=O	804		
O-H	463		
Total energy to make all the bonds in the products =			

- (ii) Using the total energy to **break** all of the bonds in the reactants, your answer to (b) (i) and the relationship shown below, calculate the energy change, in kJ, for the combustion of methane.

1

$$\text{Energy change} = \frac{\text{total energy to break all the bonds in the reactants}}{\quad} - \frac{\text{total energy to make all the bonds in the products}}{\quad}$$

[Turn over



10. (continued)

- (c) Branched chain alkanes and cycloalkanes can be made by a process known as reforming.

Reforming is a chemical reaction that changes the arrangement of carbon atoms without changing the number of carbon atoms.

An example of reforming octane is shown.

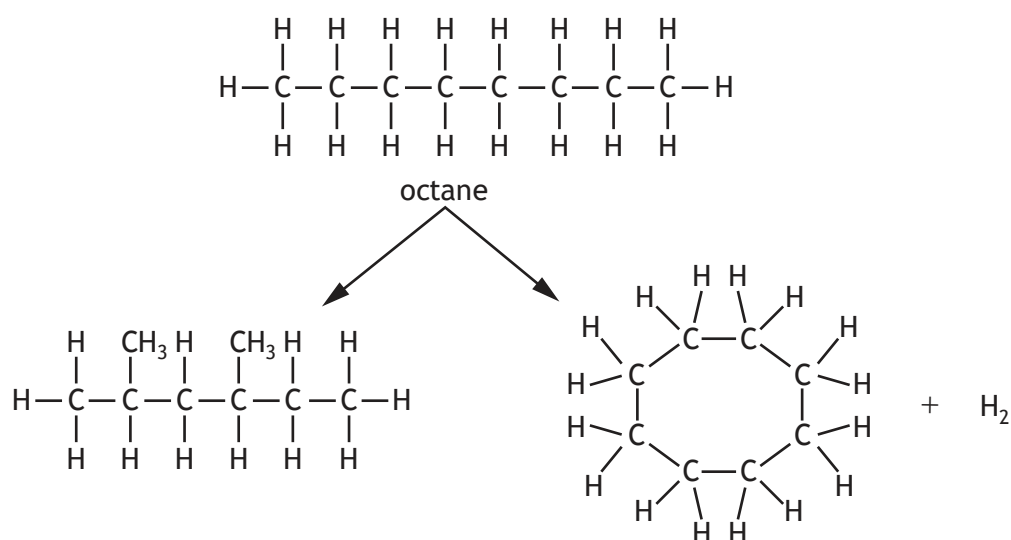

- (i) Name the branched alkane produced by the reforming of octane. 1

- (ii) Draw a structure for a cycloalkane that can be produced by the reforming of hexane. 1

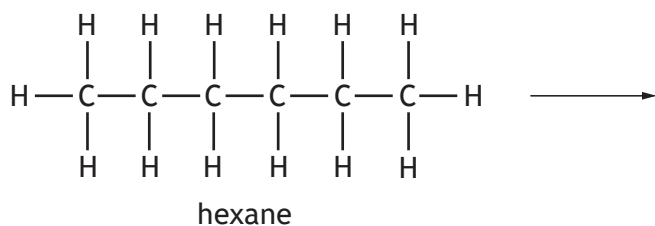

10. (d) (continued)

- (ii) Ethyne, another unsaturated hydrocarbon with a carbon to carbon triple bond, can react with water to produce ethenol.

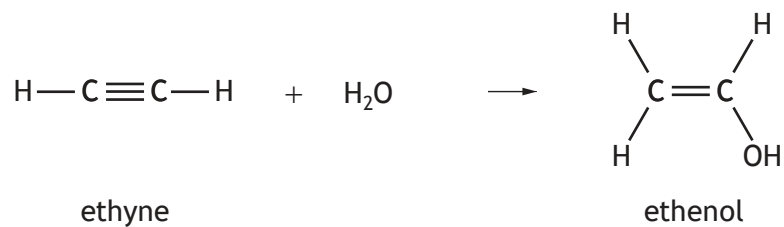

- (A) Name the polymer made from ethenol. 1
- (B) Draw the repeating unit of the polymer made from ethenol. 1



MARKS

DO NOT
WRITE IN
THIS
MARGIN

11. Radioactive decay involves changes in the nuclei of atoms.
Using your knowledge of chemistry, comment on radioactive decay.

3

[END OF QUESTION PAPER]



* X 8 1 3 7 5 0 1 3 1 *