

FOR OFFICIAL USE

| | | | | | |
|--|--|--|--|--|--|
| | | | | | |
|--|--|--|--|--|--|

X012/201

Section B Total Marks

| |
|--|
| |
|--|

NATIONAL
QUALIFICATIONS
2008

FRIDAY, 30 MAY
9.00 AM – 11.00 AM

CHEMISTRY
INTERMEDIATE 2

Fill in these boxes and read what is printed below.

Full name of centre

| |
|--|
| |
|--|

Town

| |
|--|
| |
|--|

Forename(s)

| |
|--|
| |
|--|

Surname

| |
|--|
| |
|--|

Date of birth

Day Month Year

| | | | | | | | |
|--|--|--|--|--|--|--|--|
| | | | | | | | |
|--|--|--|--|--|--|--|--|

Scottish candidate number

| | | | | | | | | | |
|--|--|--|--|--|--|--|--|--|--|
| | | | | | | | | | |
|--|--|--|--|--|--|--|--|--|--|

Number of seat

| |
|--|
| |
|--|

Necessary data will be found in the Chemistry Data Booklet for Standard Grade and Intermediate 2.

Section A – Questions 1–30 (30 marks)

Instructions for completion of **Section A** are given on page two.

For this section of the examination you must use an **HB pencil**.

Section B (50 marks)

All questions should be attempted.

The questions may be answered in any order but all answers are to be written in the spaces provided in this answer book, **and must be written clearly and legibly in ink**.

Rough work, if any should be necessary, should be written in this book, and then scored through when the fair copy has been written. If further space is required, a supplementary sheet for rough work may be obtained from the invigilator.

Additional space for answers will be found at the end of the book. If further space is required, supplementary sheets may be obtained from the invigilator and should be inserted inside the **front** cover of this booklet.

Before leaving the examination room you must give this book to the invigilator. If you do not, you may lose all the marks for this paper.



Read carefully

- 1 Check that the answer sheet provided is for **Chemistry Intermediate 2 (Section A)**.
- 2 For this section of the examination you must use an **HB pencil** and, where necessary, an eraser.
- 3 Check that the answer sheet you have been given has **your name, date of birth, SCN** (Scottish Candidate Number) and **Centre Name** printed on it.
Do not change any of these details.
- 4 If any of this information is wrong, tell the Invigilator immediately.
- 5 If this information is correct, **print** your name and seat number in the boxes provided.
- 6 The answer to each question is **either** A, B, C or D. Decide what your answer is, then, using your pencil, put a horizontal line in the space provided (see sample question below).
- 7 There is **only one correct** answer to each question.
- 8 Any rough working should be done on the question paper or the rough working sheet, **not** on your answer sheet.
- 9 At the end of the exam, put the **answer sheet for Section A inside the front cover of this answer book**.

Sample Question

To show that the ink in a ball-pen consists of a mixture of dyes, the method of separation would be

- A chromatography
- B fractional distillation
- C fractional crystallisation
- D filtration.

The correct answer is **A**—chromatography. The answer **A** has been clearly marked in **pencil** with a horizontal line (see below).

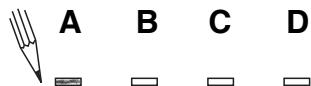

Changing an answer

If you decide to change your answer, carefully erase your first answer and using your pencil, fill in the answer you want. The answer below has been changed to **D**.



SECTION A

1. Which of the following pairs of reactants would produce hydrogen most slowly?
- A Magnesium powder and 4 mol l^{-1} acid
 - B Magnesium ribbon and 2 mol l^{-1} acid
 - C Magnesium powder and 2 mol l^{-1} acid
 - D Magnesium ribbon and 4 mol l^{-1} acid

2. Vinegar can be made by dissolving ethanoic acid in water.
- Which term describes the water used when making the vinegar?
- A Solute
 - B Saturated
 - C Solvent
 - D Solution

3. Which of the following is an element?
- A Ammonia
 - B Carbon dioxide
 - C Fluorine
 - D Methane

4. An atom is neutral because
- A the number of electrons equals the total number of protons plus neutrons
 - B the number of neutrons equals the total number of electrons plus protons
 - C the number of protons equals the number of neutrons
 - D the number of electrons equals the number of protons.

5. Which of the following is the electron arrangement for a noble gas?
- (You may wish to use page 1 of the data booklet to help you.)
- A 2, 5
 - B 2, 6
 - C 2, 7
 - D 2, 8

6. The table shows information about an **ion**.

| Particle | Number |
|-----------|--------|
| protons | 19 |
| neutrons | 20 |
| electrons | 18 |

The charge on the ion is

- A 1+
 - B 1-
 - C 2+
 - D 2-
7. Which of the following diagrams could be used to represent the structure of a metal?

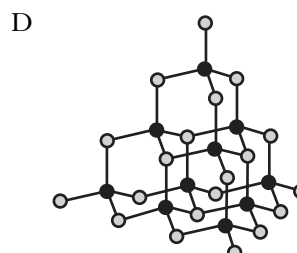
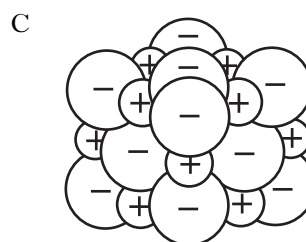
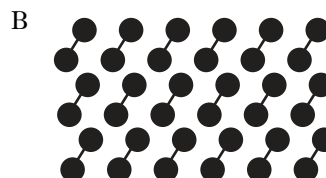
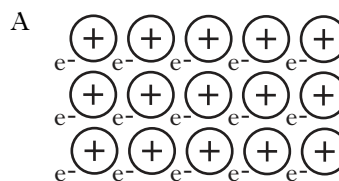

8. When methane burns in a plentiful supply of air, the products are

- A carbon monoxide and water vapour
- B carbon and water vapour
- C carbon dioxide and hydrogen
- D carbon dioxide and water vapour.

9. How many moles are present in 1.7 g of ammonia, NH_3 ?

- A 0.1
- B 1.0
- C 1.7
- D 17

10. Which line in the table shows the properties of an ionic compound?

| | Melting point ($^{\circ}\text{C}$) | Boiling point ($^{\circ}\text{C}$) | Conducts electricity? | |
|---|--------------------------------------|--------------------------------------|-----------------------|--------|
| | | | Solid | Liquid |
| A | 181 | 1347 | yes | yes |
| B | -95 | 69 | no | no |
| C | 686 | 1330 | no | yes |
| D | 1700 | 2230 | no | no |

11. The fractional distillation of crude oil produces a number of different fractions.

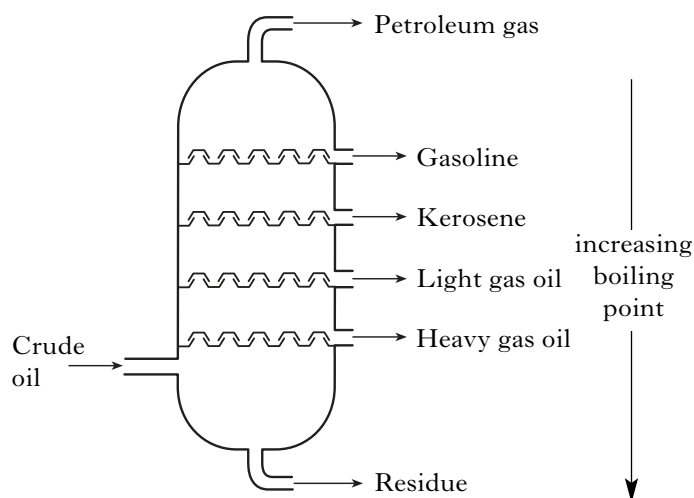

Compared with the gasoline fraction, the heavy gas oil fraction is

- A less viscous and evaporates more readily
- B more viscous and evaporates more readily
- C less viscous and evaporates less readily
- D more viscous and evaporates less readily.

12.

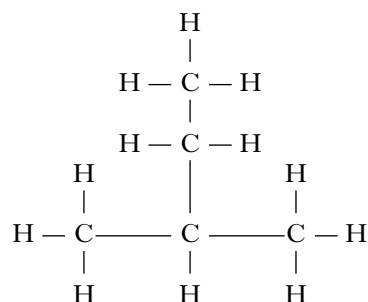

The name of the above compound is

- A 1, 1-dimethylpropane
- B 2-ethylpropane
- C 2-methylbutane
- D 3-methylbutane.

13. Which of the following compounds fits the general formula, C_nH_{2n} , and will rapidly decolourise bromine solution?

- A Cyclopentane
- B Cyclopentene
- C Pentane
- D Pentene

14. Three members of the cycloalkene homologous series are:

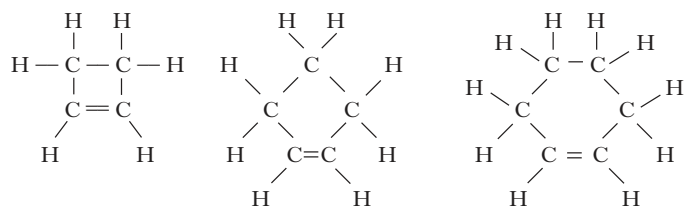

The general formula for this homologous series is

- A C_nH_{2n+2}
 B C_nH_{2n}
 C C_nH_{2n-2}
 D C_nH_{2n-4}
15. Which of the following molecules is an isomer of heptane?

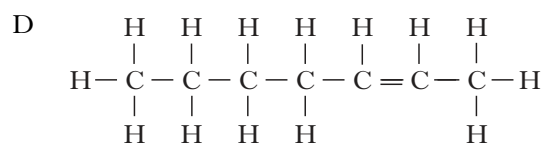
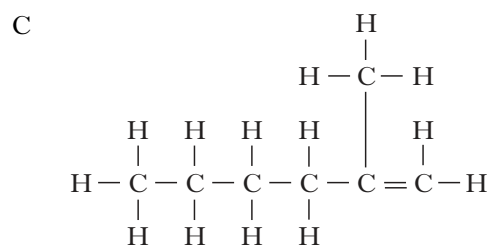
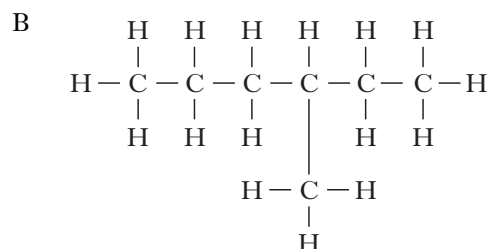
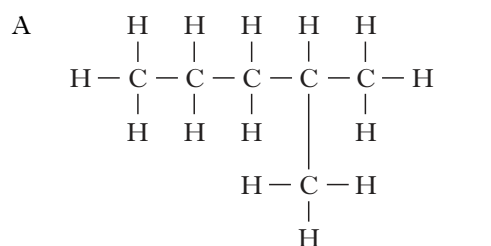

16. Fermentation of glucose to ethanol and carbon dioxide by yeast stops when the ethanol concentration reaches about 13%.

This is because

- A the ethanol has destroyed the yeast
 B all the glucose has been used up
 C carbon dioxide is harmful to yeast
 D the mixture is now saturated with ethanol.

- 17.

methanol + ethanoic acid \rightarrow methyl ethanoate + water

This reaction is an example of

- A addition
 B dehydration
 C condensation
 D neutralisation.

18. The flow diagram shows the manufacture of polythene from hydrocarbons in crude oil.

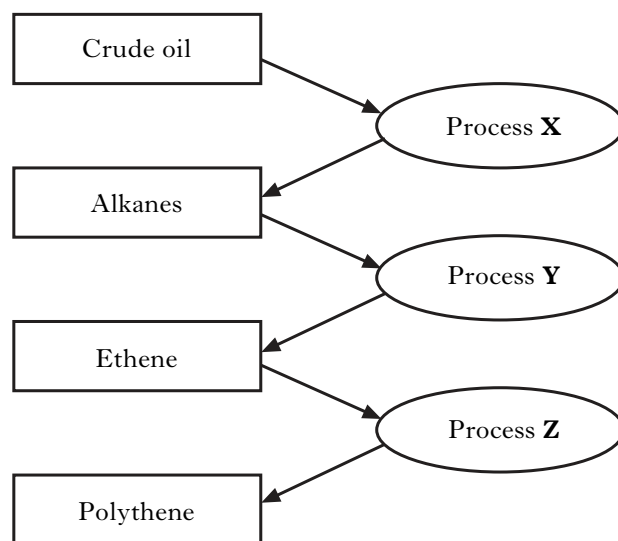

Which line in the table identifies processes **X**, **Y** and **Z**?

| | Process X | Process Y | Process Z |
|---|----------------|--------------|----------------|
| A | distillation | cracking | hydrolysis |
| B | cracking | combustion | polymerisation |
| C | polymerisation | distillation | hydrolysis |
| D | distillation | cracking | polymerisation |

19. Which of the following structures is that of an amino acid?

A

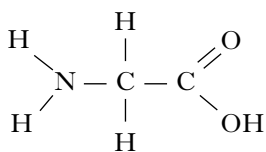

B

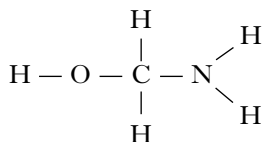

C

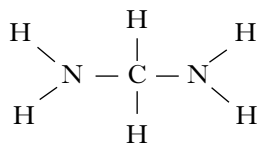

D

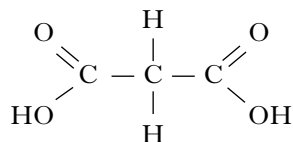

20. Compared with oils, fats are

- A less saturated and have higher melting points
- B less saturated and have lower melting points
- C more saturated and have higher melting points
- D more saturated and have lower melting points.

21. A neutral solution contains

- A neither hydrogen ions nor hydroxide ions
- B equal numbers of hydrogen ions and hydroxide ions
- C more hydrogen ions than hydroxide ions
- D more hydroxide ions than hydrogen ions.

22. Which of the following oxides will dissolve in water to produce an alkaline solution?

(You may wish to use page 5 of the data booklet to help you.)

- A Carbon dioxide
- B Copper(II) oxide
- C Potassium oxide
- D Nitrogen dioxide

23. 1 mole of sodium chloride can be used to prepare

- A 250 cm³ of a 0.4 mol l⁻¹ solution
- B 250 cm³ of a 4 mol l⁻¹ solution
- C 200 cm³ of a 0.5 mol l⁻¹ solution
- D 200 cm³ of a 1 mol l⁻¹ solution.

24. Compared to a 1 mol l⁻¹ solution of hydrochloric acid, a 1 mol l⁻¹ solution of ethanoic acid will

- A have a higher pH and react more slowly with magnesium
- B have a higher pH and react more quickly with magnesium
- C have a lower pH and react more slowly with magnesium
- D have lower pH and react more quickly with magnesium.

25. Hydrogen gas

- A burns with a pop
- B relights a glowing splint
- C turns damp pH paper red
- D turns limewater cloudy.

26.

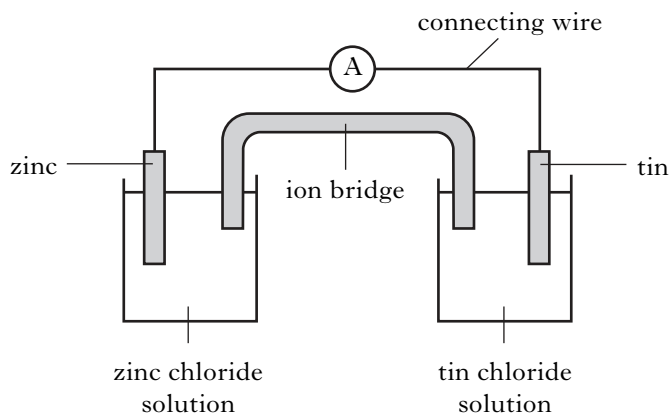

In the cell shown, electrons flow through

- A the solution from tin to zinc
- B the solution from zinc to tin
- C the connecting wire from tin to zinc
- D the connecting wire from zinc to tin.

27. Four cells were made by joining copper, iron, tin and zinc to silver. The voltages are shown in the table.

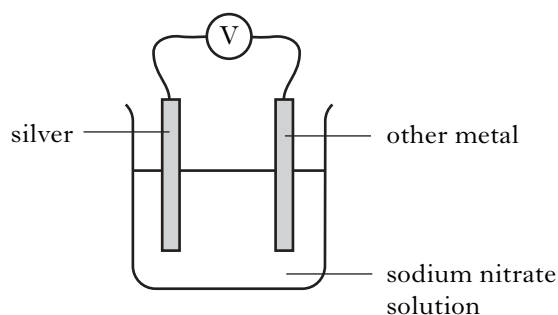

Which line in the table shows the voltage of the cell containing copper joined to silver?

(You may wish to use page 7 of the data booklet to help you.)

| Cell | Voltage (V) |
|------|-------------|
| A | 1.6 |
| B | 1.2 |
| C | 0.9 |
| D | 0.5 |

28. Which of the following metals is found uncombined in the Earth's crust?

- A Aluminium
- B Iron
- C Lead
- D Silver

29. Which ion gives a blue colour with ferroxyl indicator?

- A $H^+(aq)$
- B $OH^-(aq)$
- C $Fe^{2+}(aq)$
- D $Fe^{3+}(aq)$

30. Which of the following methods can give both physical and sacrificial protection to iron?

- A Painting
- B Greasing
- C Tin-plating
- D Galvanising

Candidates are reminded that the answer sheet for Section A MUST be placed INSIDE the front cover of this answer book.

Marks

SECTION B**50 marks are available in this section of the paper.****All answers must be written clearly and legibly in ink.**

1. (a) To which family of metals does copper belong?
(You may wish to use page 8 of the data booklet to help you.)

1

- (b) Copper is made up of two different types of atom.
(i) Complete the table to show the numbers of protons and neutrons in each type of copper atom.

| | Number of protons | Number of neutrons |
|-------------------------|-------------------|--------------------|
| ${}^{63}_{29}\text{Cu}$ | | |
| ${}^{65}_{29}\text{Cu}$ | | |

2

- (ii) What term is used to describe the different types of copper atom?

1**(4)**

Marks

2. The graph shows how the solubility of potassium chloride changes with temperature.

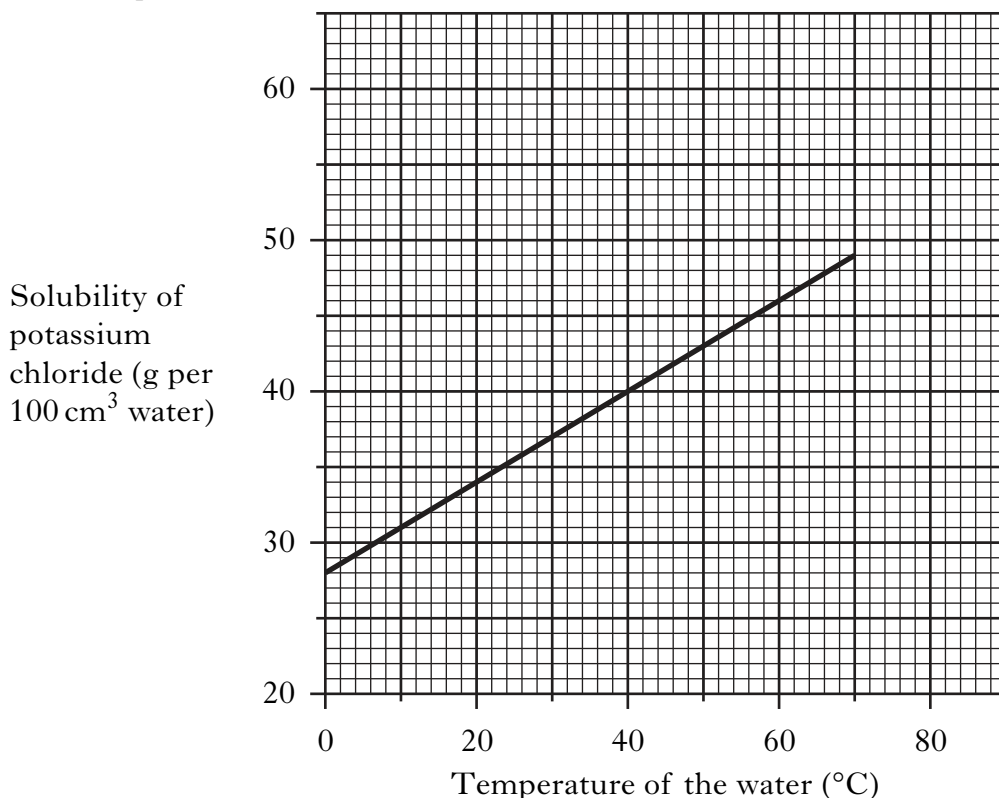

- (a) From the graph, what is the maximum mass of potassium chloride that will dissolve at 60 °C?

_____ g per 100cm³

1

- (b) The potassium chloride solution is cooled from 60 °C to 30 °C. A solid forms at the bottom of the beaker.

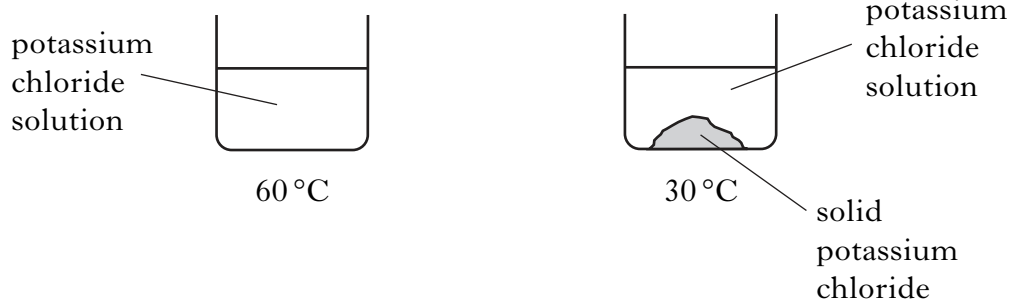

- (i) Using the graph, calculate the mass of solid potassium chloride formed at the bottom of the beaker at 30 °C.

_____ g 1

- (ii) What method could be used to separate the solid which forms?

_____ 1
(3)

Marks

3. When dinitrogen oxide, N_2O , is mixed with methane in the presence of a palladium catalyst, an explosive reaction takes place.

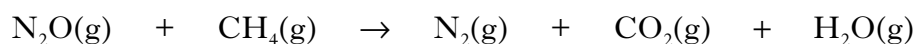

(a) Balance the above equation.

1

(b) Why can the palladium metal be described as a heterogeneous catalyst?

1

(c) The diagrams below show a possible model for palladium metal catalysing the reaction between dinitrogen oxide and methane.

Stage 1

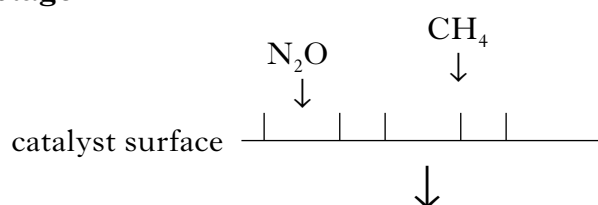

Statement

Reactants are adsorbed on to the catalyst surface.

Stage 2

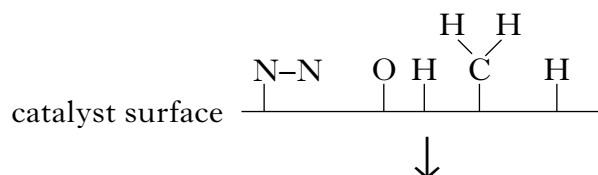

Bonds break.

Stage 3

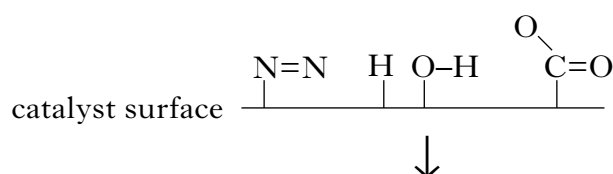

New bonds form.

Stage 4

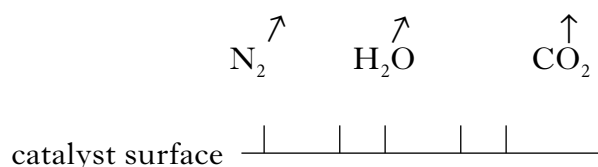

Add a statement describing what happens at **Stage 4**.

1

Marks

3. (continued)

(d) The presence of sulphur in methane gas can prevent the reaction from taking place.

Why would the presence of sulphur prevent the catalyst from working?

**1
(4)**

[Turn over

Marks

4. In a **PPA**, a solution of copper (II) chloride was electrolysed.

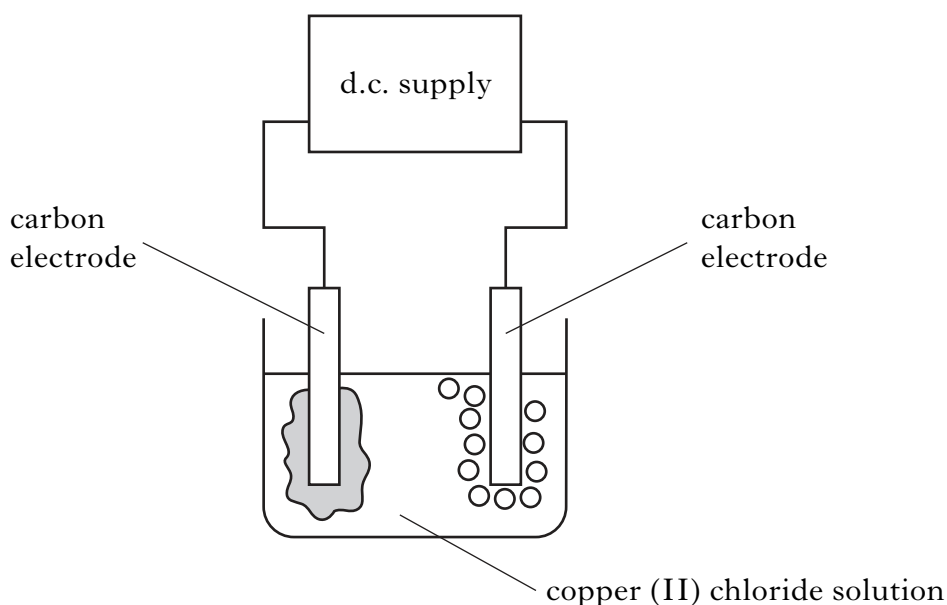

- (a) What is meant by electrolysis?

1

- (b) Why is it necessary to use a d.c. supply in electrolysis?

1

- (c) (i) Complete the table by adding the charge for each electrode.

| Observation at _____ | Observation at _____ |
|-------------------------|-------------------------|
| electrode | electrode |
| bubbles of gas | brown solid formed |

1

- (ii) How could the gas be identified?

1

(4)

Marks

5. Chlorofluorocarbons (CFCs) are a family of compounds which are highly effective as refrigerants and aerosol propellants. However, they are now known to damage the ozone layer.

One example of a CFC molecule is shown.

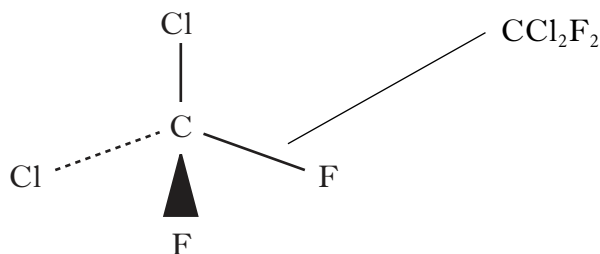

- (a) What term is used to describe the **shape** of this molecule?

1

- (b) Scientists have developed compounds to replace CFCs. The table shows information about the ratio of atoms in CCl_2F_2 and compounds used to replace it.

| Compound | Number of atoms | | | | Atmospheric life (years) |
|--------------------------|-----------------|----|---|---|--------------------------|
| | C | Cl | F | H | |
| CCl_2F_2 | 1 | 2 | 2 | 0 | 102 |
| Replacement 1 | 1 | 1 | 2 | 1 | 13.3 |
| Replacement 2 | 2 | 0 | 4 | 2 | 14.6 |
| Replacement 3 | 1 | 0 | 2 | 2 | 5.6 |

- (i) Draw a possible structure for Replacement 2.

1

- (ii) Compared with CCl_2F_2 , the replacement compounds contain less of which element?

1

- (iii) From the table, what is the advantage of using the replacement molecules as refrigerants and aerosol propellants?

1

(4)

Marks

6. Poly(ethenol) is one of the substances used to cover dishwasher tablets.



A section of the poly(ethenol) polymer is shown.

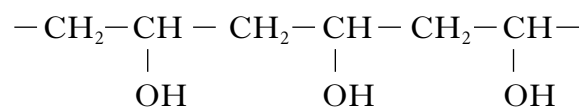

- (a) Name the functional group present in this polymer.

1

- (b) Draw the structure of the repeating unit for this polymer.

1

- (c) A dishwasher tablet, complete with its poly(ethenol) cover, can be added to a dishwasher.

What property of the poly(ethenol) makes it suitable as a cover for a dishwasher tablet?

1

(3)

Marks

7. Scientists have replaced oils in gloss paints with synthetic polyesters. This has improved the drying quality of the paint.

The first step in the production of the synthetic polyester is shown.

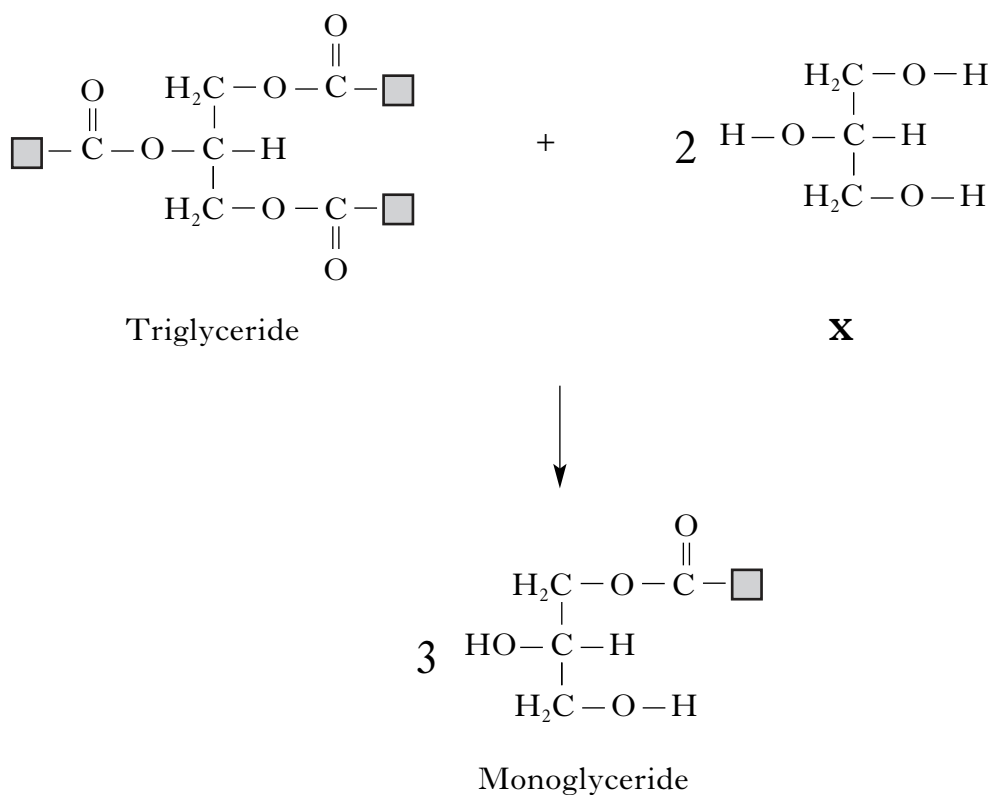

- (a) What does the term synthetic mean?

_____ 1

- (b) Circle an ester link in the triglyceride.

1

- (c) Name **X**.

_____ 1
(3)

[Turn over

Marks

8. Infrared spectroscopy can be used to detect the bonds present in molecules. The same bond always absorbs infrared radiation at the same wavenumber, even in different molecules.

For example, the C–H bond absorbs in the range 2800 – 3000 wavenumbers.

The infrared spectra of two different organic compounds are shown.

propane

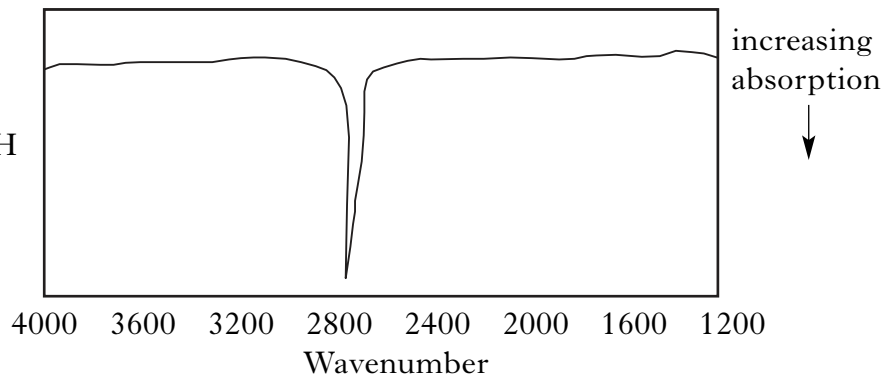
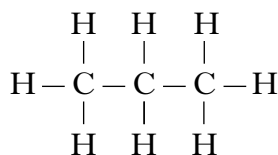

butene

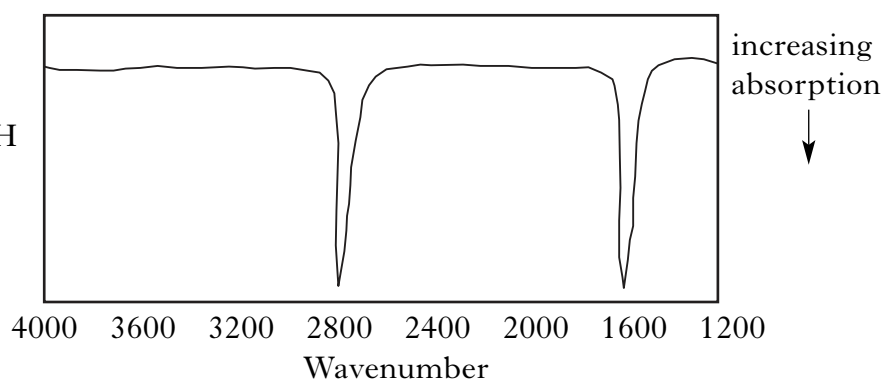
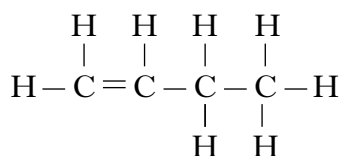

- (a) The absorption at wavenumber 1600 in the spectrum of butene is not present in the spectrum of propane.

Which bond could be responsible for this absorption?

1

- (b) The O–H bond absorbs in the range 3500 – 3700 wavenumbers.

Sketch the infrared spectrum you would predict for ethanol.

ethanol

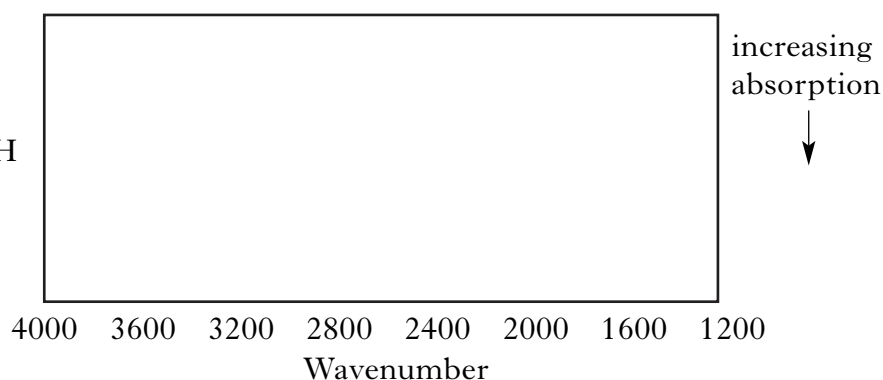
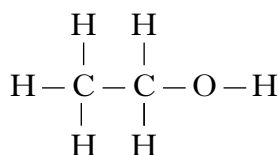
1
(2)

9. The enzyme phosphorylase catalyses the formation of starch from sugars.

(a) Name the monomer used to make a starch polymer.

Marks

1

(b) Name the solution used to test for starch.

1

(c) A student investigated the effect of temperature on the rate of starch formation. The results are shown.

| Temperature (°C) | Relative rate $1/t$ (s^{-1}) |
|------------------|----------------------------------|
| 4 | 0.003 |
| 12 | 0.010 |
| 16 | 0.016 |
| 20 | 0.022 |
| 24 | 0.033 |

(i) Plot these results as a line graph.

(Additional graph paper, if required, can be found on page 24.)

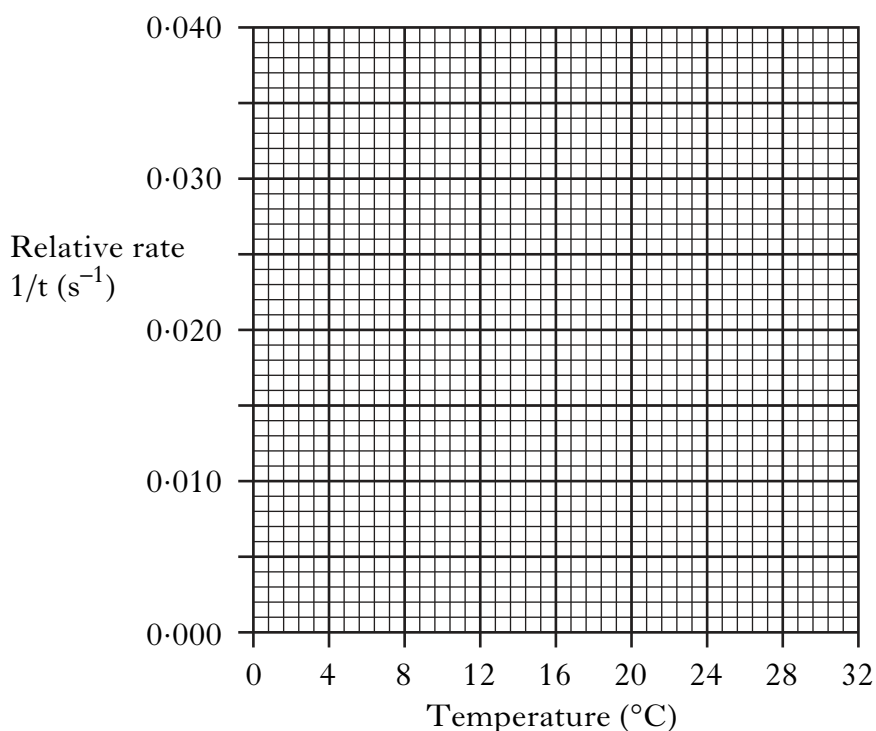

1

(ii) At 32 °C the relative rate was $0.0125s^{-1}$.

Use this rate to calculate the reaction time at 32 °C.

_____ seconds

1

(4)

10. **The Acid Test**

Adapted from Robert I. Wolke
November 2004

Seviche, a seafood dish, is described as "cooked" by marinating it in lime juice. Is it really "cooked" or is it still raw?

The citric acid in lime juice changes the proteins in fish. The normally twisted and folded protein molecules become unravelled and so the texture and colour of the fish change. This is known as denaturing.

Cooking also denatures proteins. The bonds that keep the protein twisted and folded are broken by heating the protein.

There are other methods which can be used to change the shape of proteins. Each method is complementary. For example, the stronger the acid that a protein is subjected to, the shorter the cooking time; the higher the temperature the shorter the cooking time.

Fish can therefore be cooked without heating it!

Marks

Use the article to answer the following questions.

- (a) Proteins can be denatured.

Describe what happens to the protein when it is denatured.

1

- (b) Other than heat, give a method that could be used to "cook" fish.

1

- (c) Proteins can be denatured at low temperatures.

What does this suggest about the strength of the bonds keeping the protein twisted and folded?

1

- (d) Draw a graph to show the relationship between cooking temperature and the cooking time for fish.

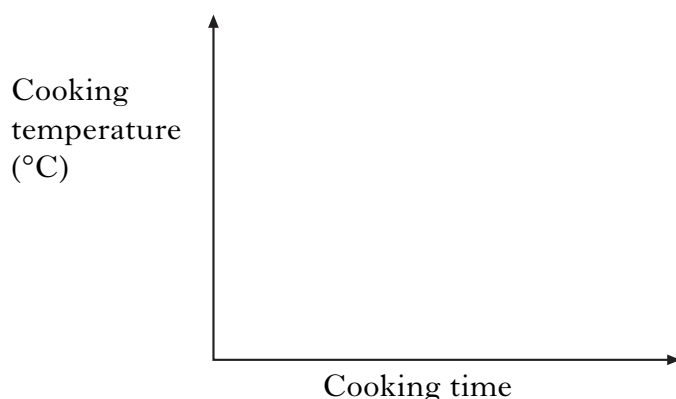

1

(4)

Marks

11. Silver jewellery slowly tarnishes in air. This is due to the formation of silver(I) sulphide.

The silver(I) sulphide can be converted back to silver using the following apparatus.

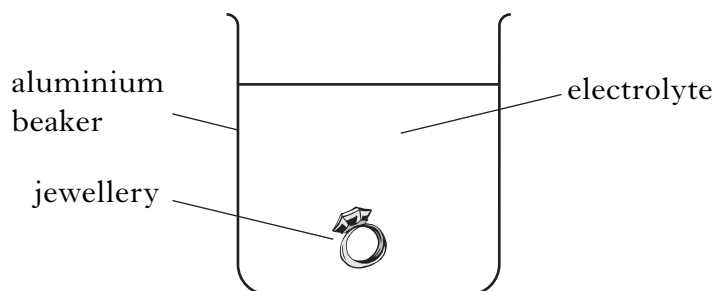

The equation for the reaction which takes place in the beaker is shown.

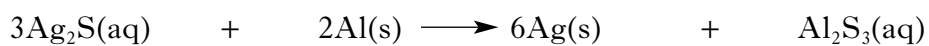

(a) Calculate the mass of silver produced when 0.135 g of aluminium is used up.

_____ g 2

(b) How would you show that aluminium has been lost from the beaker during this reaction?

_____ 1
(3)

[Turn over

Marks

12. Many medicines are available as tablets which dissolve readily in water. These tablets contain solid citric acid and sodium hydrogencarbonate.

(a) When the tablet is added to water the citric acid reacts with the sodium hydrogencarbonate giving off a gas.

Name the gas produced.

1

(b) The structure of citric acid is shown below.

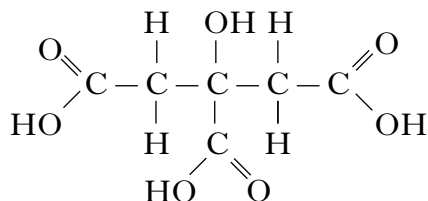

Write the molecular formula for citric acid.

1

(c) In aqueous solution, citric acid molecules are only partially dissociated. What term is used to describe this type of acid?

1**(3)**

Marks

13. Strontium nitrate is used in fireworks. The flow chart shows how strontium nitrate can be produced.

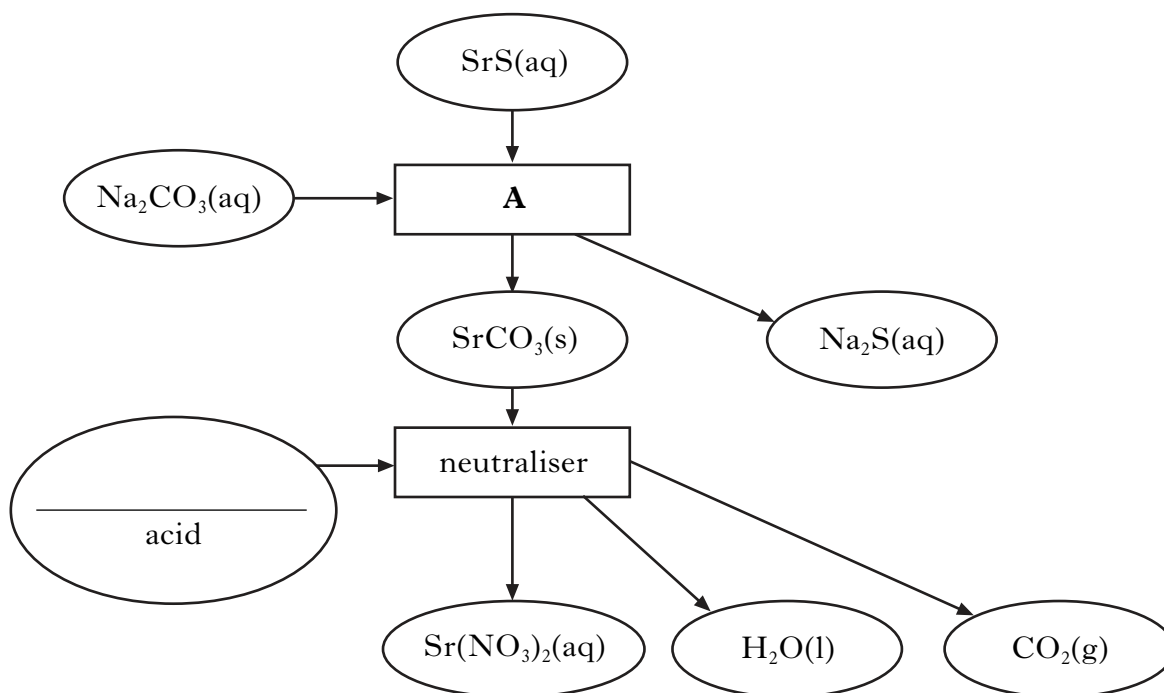

- (a) Name the type of chemical reaction taking place at **A**.

_____ 1

- (b) Complete the flow chart by adding the name of the acid used to form the salt, strontium nitrate.

_____ 1

- (c) What colour would be seen when a firework containing strontium nitrate is set off?

(You may wish to use page 4 of the data booklet to help you.)

_____ 1

(3)

[Turn over

Marks

14. A number of electrochemical cells are being developed.

One such example is the aluminium/air cell. It is used as a back-up power supply in telephone exchanges.

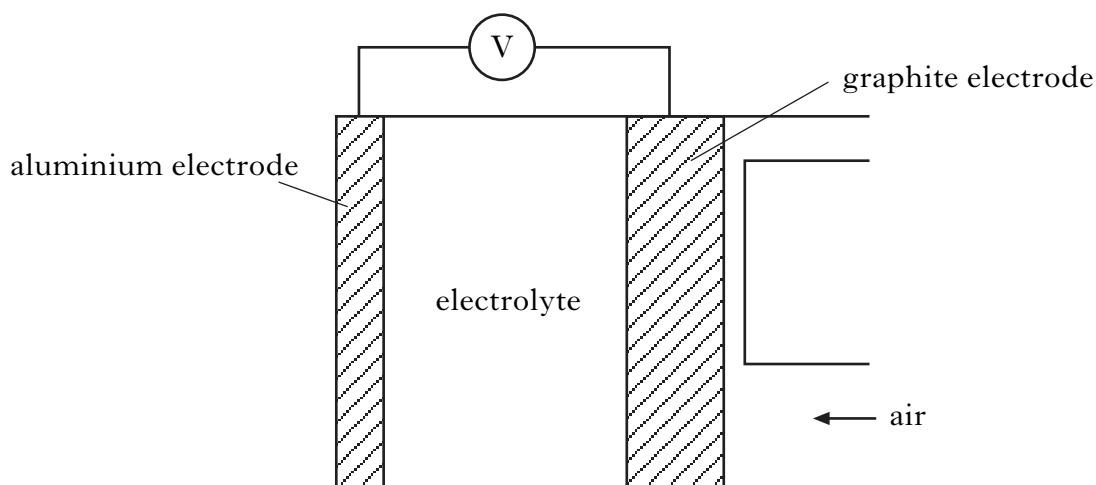

(a) What is the purpose of the electrolyte in the cell?

1

(b) The ion-electron equations for the reactions taking place at the electrodes are:

| | |
|----------------------------|---|
| aluminium electrode | $\text{Al} \rightarrow \text{Al}^{3+} + 3\text{e}^{-}$ |
| graphite electrode | $\text{O}_2 + 2\text{H}_2\text{O} + 4\text{e}^{-} \rightarrow 4\text{OH}^{-}$ |

(i) What process has the aluminium electrode undergone?

1

(ii) When the cell is operating, a solid forms in the electrolyte. Identify the solid.

(You may wish to use page 5 of the data booklet to help you.)

1
(3)

Marks

15. A student's report is shown for the PPA "Reactions of Metals with Oxygen".

Title. Reactions of Metals with Oxygen. **Date.** 15/11/07

Aim. The aim of the experiment was to place zinc, copper and magnesium in order of reactivity.

Procedure. The apparatus required to carry out the experiment was collected and assembled as shown.

Results

| Metal | Observations |
|-----------|--------------------------|
| zinc | moderately fast reaction |
| magnesium | fast reaction |
| copper | slow reaction |

- (a) Write the formula for potassium permanganate.
(You may wish to use page 4 of the data booklet to help you.)

1

- (b) Why is potassium permanganate used in the experiment?

1

- (c) For safety reasons it is recommended that metal powders should not be used when carrying out this experiment.

Suggest why metal powders should **not** be used.

1

(3)

[END OF QUESTION PAPER]

ADDITIONAL SPACE FOR ANSWERS

ADDITIONAL GRAPH PAPER FOR QUESTION 9(c)(i)

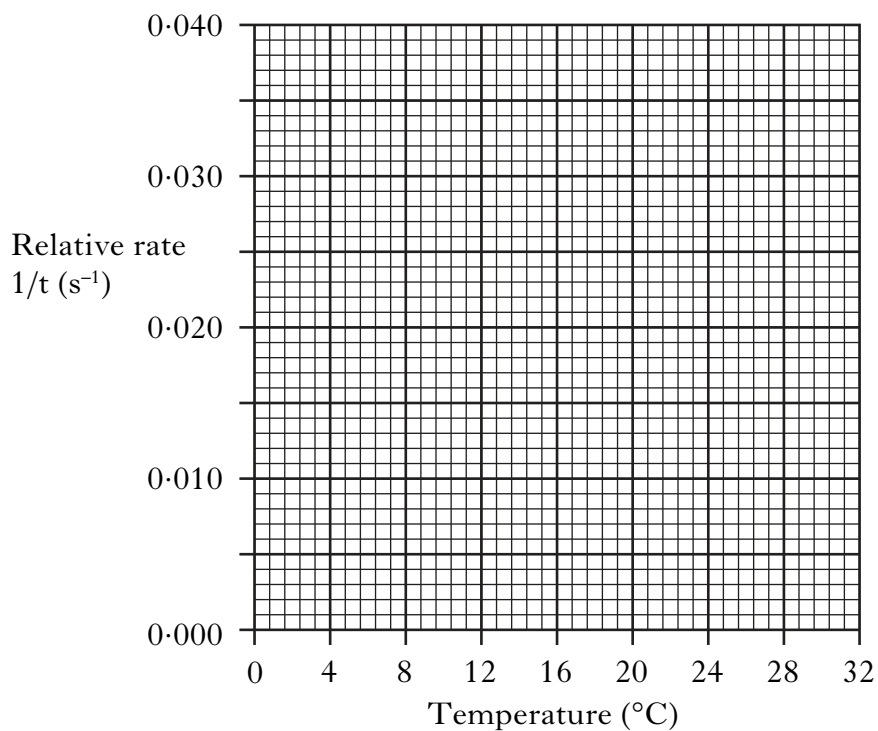

ADDITIONAL SPACE FOR ANSWERS

| |
|--|
| |
|--|

ADDITIONAL SPACE FOR ANSWERS

| |
|--|
| |
|--|

ADDITIONAL SPACE FOR ANSWERS

| |
|--|
| |
|--|

ACKNOWLEDGEMENTS

Section B Question 10—Extract adapted from *The Acid Test* by Robert I Wolke.
Permission is being sought from The Washington Post.