

FOR OFFICIAL USE

--	--	--	--	--	--

Section B

Total  
Marks

--

**X012/201**

NATIONAL  
QUALIFICATIONS  
2010

WEDNESDAY, 2 JUNE  
9.00 AM – 11.00 AM

CHEMISTRY  
INTERMEDIATE 2

Fill in these boxes and read what is printed below.

Full name of centre

--

Town

--

Forename(s)

--

Surname

--

Date of birth

Day    Month    Year

--	--	--	--	--	--

Scottish candidate number

--	--	--	--	--	--	--	--	--	--

Number of seat

--

Necessary data will be found in the Chemistry Data Booklet for Standard Grade and Intermediate 2.

**Section A – Questions 1–30 (30 marks)**

Instructions for completion of **Section A** are given on page two.

For this section of the examination you must use an **HB pencil**.

**Section B (50 marks)**

All questions should be attempted.

The questions may be answered in any order but all answers are to be written in the spaces provided in this answer book, **and must be written clearly and legibly in ink**.

Rough work, if any should be necessary, should be written in this book, and then scored through when the fair copy has been written. If further space is required, a supplementary sheet for rough work may be obtained from the Invigilator.

Additional space for answers will be found at the end of the book. If further space is required, supplementary sheets may be obtained from the Invigilator and should be inserted inside the **front** cover of this booklet.

Before leaving the examination room you must give this book to the Invigilator. If you do not, you may lose all the marks for this paper.



### Read carefully

- 1 Check that the answer sheet provided is for **Chemistry Intermediate 2 (Section A)**.
- 2 For this section of the examination you must use an **HB pencil** and, where necessary, an eraser.
- 3 Check that the answer sheet you have been given has **your name, date of birth, SCN** (Scottish Candidate Number) and **Centre Name** printed on it.  
Do not change any of these details.
- 4 If any of this information is wrong, tell the Invigilator immediately.
- 5 If this information is correct, **print** your name and seat number in the boxes provided.
- 6 The answer to each question is **either** A, B, C or D. Decide what your answer is, then, using your pencil, put a horizontal line in the space provided (see sample question below).
- 7 There is **only one correct** answer to each question.
- 8 Any rough working should be done on the question paper or the rough working sheet, **not** on your answer sheet.
- 9 At the end of the examination, put the **answer sheet for Section A inside the front cover of this answer book**.

### Sample Question

To show that the ink in a ball-pen consists of a mixture of dyes, the method of separation would be

- A chromatography
- B fractional distillation
- C fractional crystallisation
- D filtration.

The correct answer is **A**—chromatography. The answer **A** has been clearly marked in **pencil** with a horizontal line (see below).

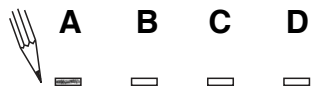

### Changing an answer

If you decide to change your answer, carefully erase your first answer and using your pencil, fill in the answer you want. The answer below has been changed to **D**.

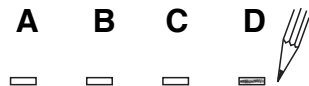

## SECTION A

1. Which of the following changes is **not** an example of a chemical reaction?

- A Ice melting
- B Iron rusting
- C Methane burning
- D Neutralising an acid

2. During the first 20 seconds of a chemical reaction,  $5.0 \text{ cm}^3$  of gas were given off.

The average rate of the reaction, in  $\text{cm}^3 \text{ s}^{-1}$ , during the first 20 seconds is

- A 20.0
- B 5.0
- C 4.0
- D 0.25.

3. Some of the bonds in an amino acid molecule are polar covalent.

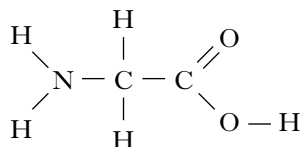

The table contains information about the attraction of some atoms for bonded electrons.

Atom	Relative attraction for bonded electrons
H	2.2
C	2.5
N	3.0
O	3.5

The most polar bond in the amino acid molecule will be

- A C — H
- B N — H
- C O — H
- D C — O.

4. Metallic bonds are due to

- A pairs of electrons being shared equally between atoms
- B pairs of electrons being shared unequally between atoms
- C the attraction of oppositely charged ions for each other
- D the attraction of positively charged ions for delocalised electrons.

5. Which of the following elements exists as diatomic molecules?

- A Carbon
- B Helium
- C Nitrogen
- D Sulphur

6. A solution containing chloride ions, fluoride ions and bromide ions was electrolysed.

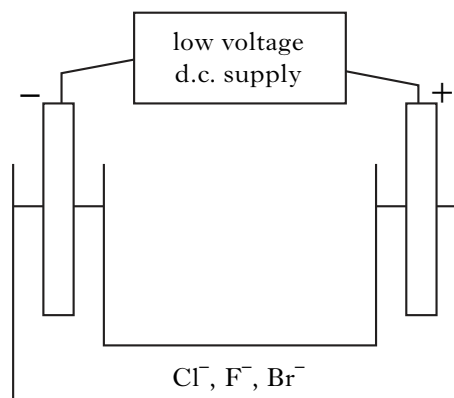

The speed at which ions move towards an electrode depends on the size of the ion.

The bigger the ion the slower it moves.

The order in which the negative ions would reach the positive electrode, from first to last, is

- A  $\text{Br}^-$ ,  $\text{Cl}^-$ ,  $\text{F}^-$
- B  $\text{Br}^-$ ,  $\text{F}^-$ ,  $\text{Cl}^-$
- C  $\text{F}^-$ ,  $\text{Br}^-$ ,  $\text{Cl}^-$
- D  $\text{F}^-$ ,  $\text{Cl}^-$ ,  $\text{Br}^-$ .

**[Turn over**

7. The formula for magnesium sulphite is

- A MgS
- B MgSO<sub>3</sub>
- C MgSO<sub>4</sub>
- D MgS<sub>2</sub>O<sub>3</sub>.

8.  $x\text{Al(s)} + y\text{Br}_2(\ell) \rightarrow z\text{AlBr}_3(\text{s})$

This equation will be balanced when

- A  $x = 1, y = 2, z = 1$
- B  $x = 2, y = 3, z = 2$
- C  $x = 3, y = 2, z = 3$
- D  $x = 4, y = 3, z = 4.$

9. The isotopes of carbon and oxygen are given in the table.

Isotopes of carbon	$^{12}_6\text{C}$	$^{13}_6\text{C}$	$^{14}_6\text{C}$
Isotopes of oxygen	$^{16}_8\text{O}$	$^{17}_8\text{O}$	$^{18}_8\text{O}$

A molecule of carbon dioxide with mass 46 could contain

- A one  $^{12}\text{C}$  atom and two  $^{16}\text{O}$  atoms
- B one  $^{14}\text{C}$  atom and two  $^{18}\text{O}$  atoms
- C one  $^{12}\text{C}$  atom, one  $^{16}\text{O}$  atom and one  $^{18}\text{O}$  atom
- D one  $^{14}\text{C}$  atom, one  $^{16}\text{O}$  atom and one  $^{18}\text{O}$  atom.

10. 1 mole of a hydrocarbon burns completely in oxygen to produce 2 moles of carbon dioxide and 2 moles of water.

The formula for the hydrocarbon is

- A C<sub>2</sub>H<sub>4</sub>
- B C<sub>2</sub>H<sub>6</sub>
- C C<sub>4</sub>H<sub>8</sub>
- D C<sub>4</sub>H<sub>10</sub>.

11. The properties of fractions obtained from crude oil depend on the sizes of molecules in the fractions.

Compared with a fraction containing small molecules, a fraction containing large molecules will

- A be more viscous
- B be more flammable
- C evaporate more readily
- D have a lower boiling point range.

12. Which of the following hydrocarbons does **not** belong to the same homologous series as the others?

- A CH<sub>4</sub>
- B C<sub>3</sub>H<sub>8</sub>
- C C<sub>4</sub>H<sub>10</sub>
- D C<sub>6</sub>H<sub>12</sub>

13. Which type of reaction is shown by the following equation?

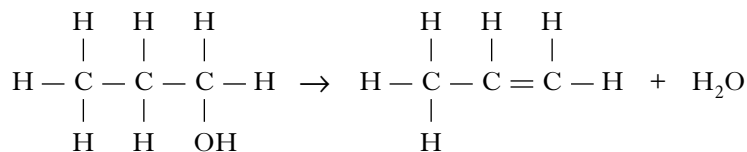

- A Condensation
- B Dehydration
- C Hydration
- D Hydrolysis

14. Which of the following polymers dissolves in water?

- A Kevlar
- B Perspex
- C Poly(ethene)
- D Poly(ethenol)

15. The structure below shows a section of an addition polymer.

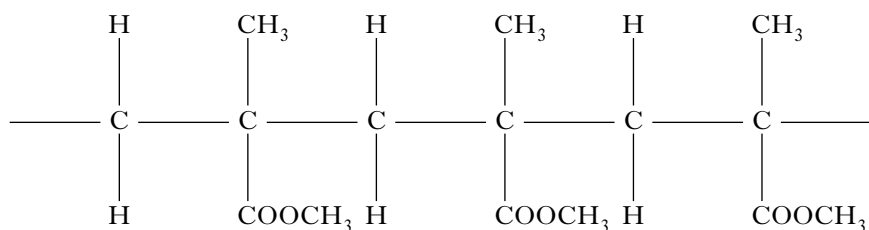

Which molecule is used to make this polymer?

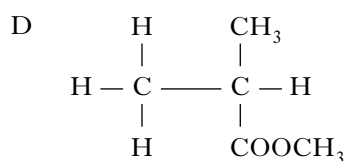
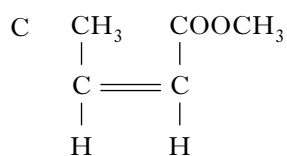
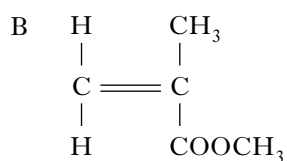
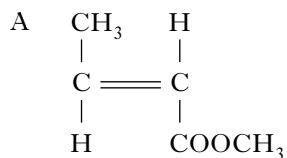

16. Which of the following groups can react together to form an amide (peptide) link?

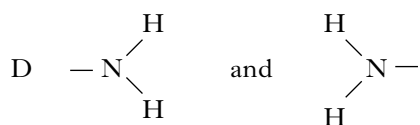
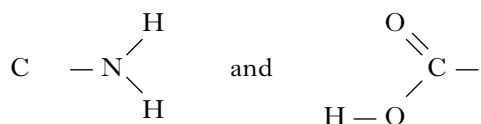
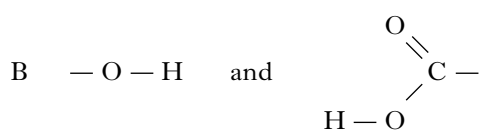
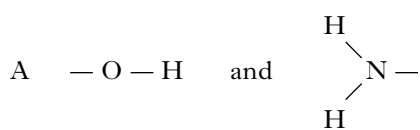

17. When a reversible reaction is at equilibrium, the concentrations of reactants and products are

- A constant but not equal
- B constant and equal
- C not constant but equal
- D not constant and not equal.

18. Which of the following substances dissolves in water to give a solution of pH greater than 7?

- A Ammonia
- B Carbon dioxide
- C Sulphur dioxide
- D Sodium chloride

[Turn over

19. An acidic solution contains
- A only hydrogen ions
  - B more hydrogen ions than hydroxide ions
  - C more hydroxide ions than hydrogen ions
  - D equal numbers of hydrogen ions and hydroxide ions.

20. What mass of ammonium sulphate,  $(\text{NH}_4)_2\text{SO}_4$ , is required to produce 0.5 litres of a  $1 \text{ mol l}^{-1}$  solution?
- A 32 g
  - B 64 g
  - C 66 g
  - D 132 g

21. Which line in the table correctly shows the properties of  $0.1 \text{ mol l}^{-1}$  hydrochloric acid when compared with  $0.1 \text{ mol l}^{-1}$  ethanoic acid?

	pH	Conductivity	Rate of reaction with magnesium
A	lower	lower	slower
B	higher	higher	faster
C	lower	higher	faster
D	higher	lower	slower

22. Which of the following potassium compounds is a base?
- A Potassium nitrate
  - B Potassium chloride
  - C Potassium sulphate
  - D Potassium carbonate

23. In a neutralisation reaction between an acid and an alkali, the pH
- A of the acid increases
  - B of the acid is unchanged
  - C of the alkali increases
  - D of the alkali is unchanged.

24. Which of the following substances will **not** produce a gas when added to dilute hydrochloric acid?

- A Copper
- B Zinc
- C Copper carbonate
- D Zinc carbonate

25. Which salt can **not** be prepared by a precipitation reaction?

(You may wish to use the data booklet to help you.)

- A Barium sulphate
- B Lead(II) sulphate
- C Calcium chloride
- D Silver chloride

26. The equation for the reaction between lead(II) nitrate and sodium iodide is:

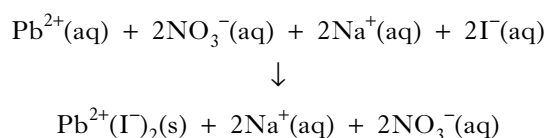

The spectator ions present in this reaction are

- A  $\text{Na}^{+}(\text{aq})$  and  $\text{NO}_3^{-}(\text{aq})$
- B  $\text{Na}^{+}(\text{aq})$  and  $\text{I}^{-}(\text{aq})$
- C  $\text{Pb}^{2+}(\text{aq})$  and  $\text{NO}_3^{-}(\text{aq})$
- D  $\text{Pb}^{2+}(\text{aq})$  and  $\text{I}^{-}(\text{aq})$ .

27. Which metal will displace zinc from a solution of zinc sulphate?

- A Iron
- B Magnesium
- C Silver
- D Tin

28. The ion-electron equation for the oxidation and reduction steps in the reaction between magnesium and silver(I) ions are:

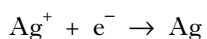

The overall redox equation is

- A  $\text{Mg} + 2\text{Ag}^{+} \rightarrow \text{Mg}^{2+} + 2\text{Ag}$   
B  $\text{Mg} + \text{Ag}^{+} \rightarrow \text{Mg}^{2+} + \text{Ag}$   
C  $\text{Mg} + \text{Ag}^{+} + \text{e}^{-} \rightarrow \text{Mg}^{2+} + \text{Ag} + 2\text{e}^{-}$   
D  $\text{Mg} + 2\text{Ag} \rightarrow \text{Mg}^{2+} + 2\text{Ag}^{+}$ .
29. Aluminium can be extracted from aluminium oxide by
- A heating alone  
B heating with carbon  
C heating with carbon monoxide  
D electrolysis.

30. An iron nail is covered with water.

Which of the following would increase the rate at which the iron nail rusts?

- A Adding glucose to the water  
B Wrapping magnesium around the nail  
C Adding potassium nitrate to the water  
D Attaching the nail to the negative terminal of a d.c. power supply

**Candidates are reminded that the answer sheet for Section A MUST be placed INSIDE the front cover of this answer book.**

**[Turn over**

**[BLANK PAGE]**

Marks

## SECTION B

50 marks are available in this section of the paper.

All answers must be written clearly and legibly in ink.

1. Elements are made up of atoms.

An atom of an element is represented by the diagram below.

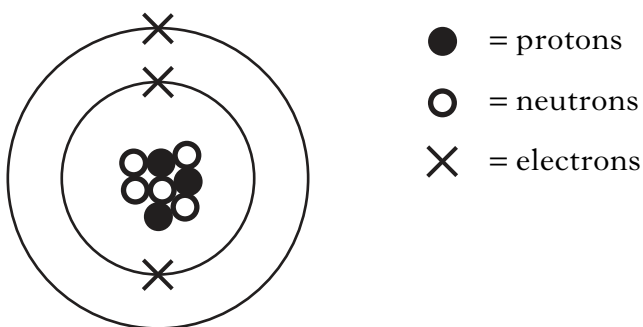

- (a) What name is given to the part of the atom which contains protons and neutrons?

\_\_\_\_\_ 1

- (b) Using the information in the diagram:

- (i) state the mass number of this atom;

\_\_\_\_\_ 1

- (ii) explain why this atom is electrically neutral;

\_\_\_\_\_  
\_\_\_\_\_ 1

- (iii) name the **family** of elements to which this atom belongs.

\_\_\_\_\_ 1  
(4)

[Turn over

Marks

2. Cool packs can be used to treat some sports injuries.



The pack contains solid ammonium nitrate and water in two separate compartments. When the pack is squeezed the ammonium nitrate dissolves in the water forming a solution. This results in a drop in temperature.

- (a) What term is used to describe a reaction in which there is a drop in temperature?

\_\_\_\_\_

1

- (b) The equation for the reaction taking place in the cool pack is shown.

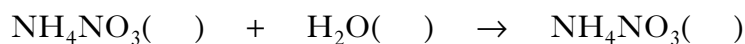

Complete the equation by adding state symbols.

1

- (c) What name is given to a liquid, such as water, that can be used to dissolve substances?

\_\_\_\_\_

1

- (d) The change in temperature in the cool pack can be calculated using the equation below.

$\text{Temperature change} = \frac{\text{energy change (kJ)}}{\text{mass of water (kg)} \times 4.2}$
--

Calculate the temperature change using the following information.

Energy change (kJ)	6.72
Mass of water (kg)	0.2

\_\_\_\_\_ °C

1

(4)

Marks

3. The element carbon can exist in the form of diamond.  
The structure of diamond is shown in the diagram.

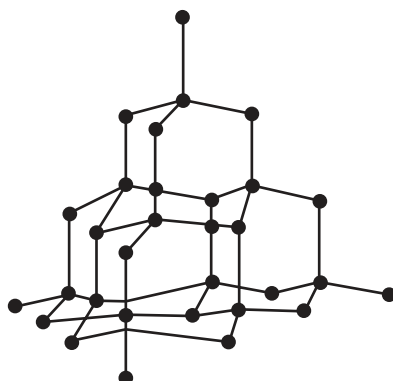

- (a) Name the type of **bonding** and **structure** present in diamond.

---

1

- (b) Carbon forms many compounds with other elements such as hydrogen.

- (i) Draw a diagram to show how the outer electrons are arranged in a molecule of methane,  $\text{CH}_4$ .

1

- (ii) Draw a diagram to show the **shape** of a molecule of methane,  $\text{CH}_4$ .

1

(3)

4. Gold is a very soft metal. In order to make it harder, goldsmiths mix it with silver. The quality of the gold is indicated in carats.

(a) The graph shows information about the quality of gold.

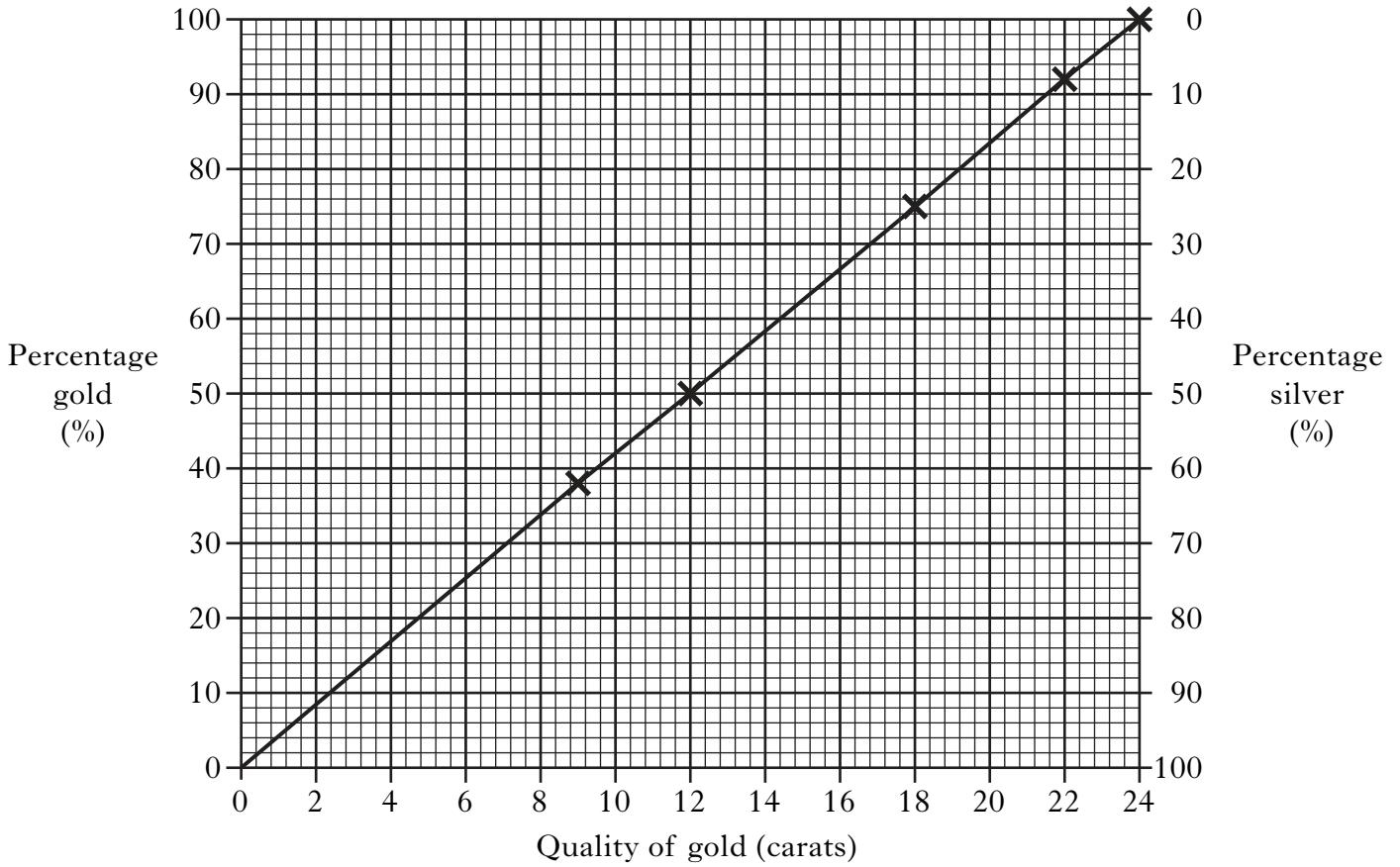

(i) What is the percentage of silver in an 18 carat gold ring?

\_\_\_\_\_ %

(ii) Calculate the mass of silver in an 18 carat gold ring weighing 6 g.

\_\_\_\_\_ g

DO NOT  
WRITE IN  
THIS  
MARGIN

Marks

1

1

*Marks***4. (continued)**

(b) Silver tarnishes in air forming black silver sulphide, Ag<sub>2</sub>S.

The equation for the reaction is:



What mass of silver sulphide would be formed from 1.08 g of silver?

2  
(4)

[Turn over

Marks

5. The diagram below shows the apparatus used in the PPA, "Cracking".

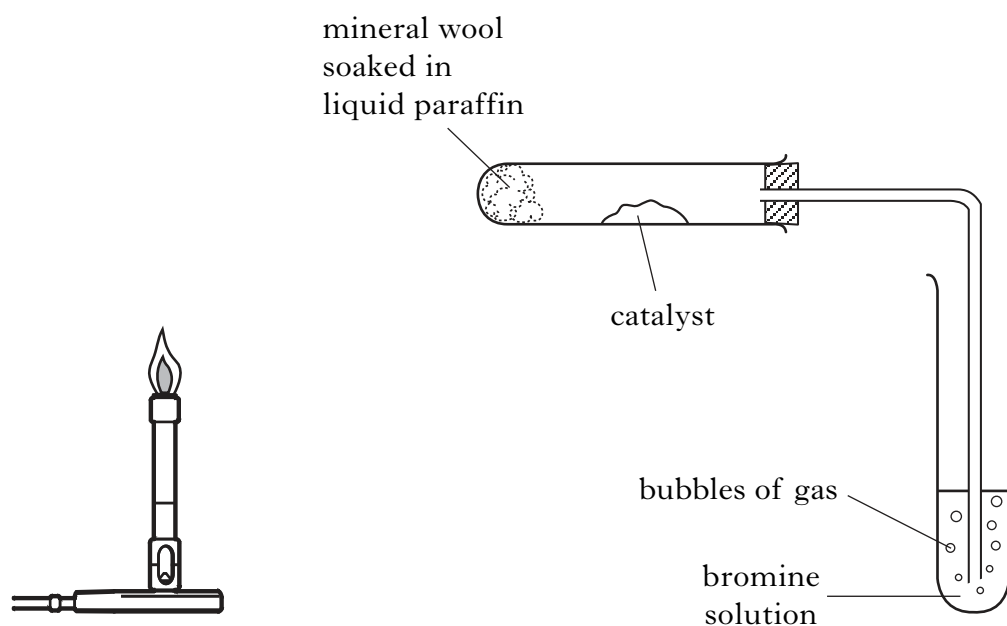

- (a) Describe how the bunsen burner is used to heat the apparatus.

\_\_\_\_\_

\_\_\_\_\_

1

- (b) Explain why the delivery tube must be removed from the bromine solution before heating is stopped.

\_\_\_\_\_

\_\_\_\_\_

1

- (c) (i) Name the catalyst that is used in this cracking reaction.

\_\_\_\_\_

1

- (ii) Catalysts speed up the rate of a reaction without being used up.  
State another reason for using a catalyst.

\_\_\_\_\_

1

- (d) One of the reactions taking place is:

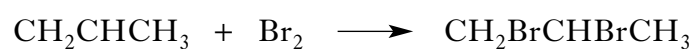

What name is given to this type of chemical reaction?

\_\_\_\_\_

1

(5)

Marks

6. Chemicals in food provide flavour and smell. Ketones are responsible for the flavour in blue cheese.

Two examples of ketones are shown below.

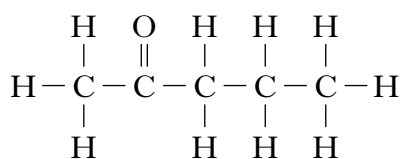

pentan-2-one

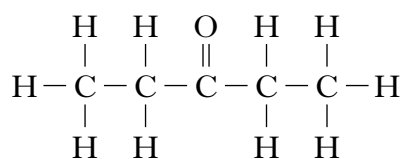

pentan-3-one

- (a) Draw a structure for hexan-3-one.

1

- (b) Suggest a name for the ketone shown below.

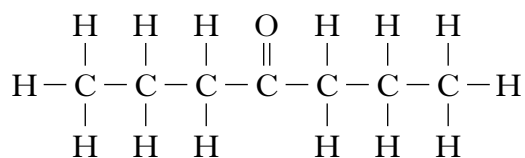

1

- (c) Information about the boiling points of four ketones is shown in the table.

Ketone	Boiling point (°C)
C <sub>3</sub> H <sub>6</sub> O	56
C <sub>4</sub> H <sub>8</sub> O	80
C <sub>5</sub> H <sub>10</sub> O	102
C <sub>6</sub> H <sub>12</sub> O	127

Predict the boiling point of C<sub>7</sub>H<sub>14</sub>O.

\_\_\_\_\_ °C

1

(3)

[Turn over

Marks

7. A recipe for making blackcurrant wine is shown.

1. Boil 4 litres of water and add 2 kg of sugar.
2. Stir until all the sugar dissolves.
3. Add 1.5 kg of crushed blackcurrants and let the mixture cool to room temperature.
4. Add some yeast.
5. Cover the container and leave it in a warm place for 5 days.
6. Filter the mixture into a glass jar and fit an airlock.
7. Leave the mixture for 3 months before filtering and bottling.

(a) Yeast is used to convert sugar into ethanol.

(i) What name is given to this process?

\_\_\_\_\_

1

(ii) What **type** of substance, found in yeast, acts as a catalyst?

\_\_\_\_\_

1

(b) Why was the mixture cooled at step 3, before the yeast was added to it?

\_\_\_\_\_

\_\_\_\_\_

1

(c) When blackcurrant brandy is made from blackcurrant wine, the ethanol concentration is increased.

How could this be done?

\_\_\_\_\_

1

(4)

*Marks*

8. Sweets, such as pineapple cubes, contain the artificial flavouring methyl butanoate.

(a) To which family of compounds does methyl butanoate belong?

\_\_\_\_\_

**1**

(b) Methyl butanoate can be broken down to form an alkanol and an alkanolic acid.

(i) Name this type of chemical reaction.

\_\_\_\_\_

**1**

(ii) Draw the full structural formula for the alkanolic acid formed from the breakdown of methyl butanoate.

**1****(3)****[Turn over**

Marks

9.

**Autumn days**

Adapted from an article by Victoria Ashton

September 2001

The leaves of a Beech tree contain three coloured pigments; chlorophyll which is green, carotenes which are yellow and tannins which are brown.

In summer, the leaves are green as they contain a lot of chlorophyll. The chlorophyll is involved in converting water and carbon dioxide into glucose and oxygen. The glucose formed can then be converted into starch by condensation polymerisation.

In autumn the chlorophyll is broken down, supplying the tree with essential magnesium ions ( $\text{Mg}^{2+}$ ) which it will need over the winter. As a result, the colours of the carotenes and tannins dominate in autumn, giving the Beech tree its golden yellow coloured leaves.

- (a) What name is given to the process, in which water and carbon dioxide are converted into glucose and oxygen?

---

1

- (b) State a test and the result that you would get, which would distinguish between glucose and starch.

---



---

1

- (c) The structure of a tannin molecule is shown below.

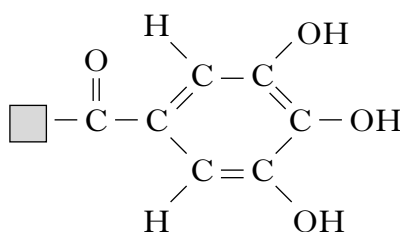

- Circle a hydroxyl group in this structure.

1

- (d) What is the electron arrangement for a magnesium ion,  $\text{Mg}^{2+}$ ?

---

1

(4)

Marks

10. People often drink lemonade to quench their thirst.

(a) Lemonade contains citric acid.

Suggest a pH value for lemonade.

---

1

(b) To make the drink fizzy, carbon dioxide gas is added to the lemonade. The solubility of carbon dioxide gas depends on the temperature of the lemonade.

The graph shows how the solubility of carbon dioxide gas changes with temperature.

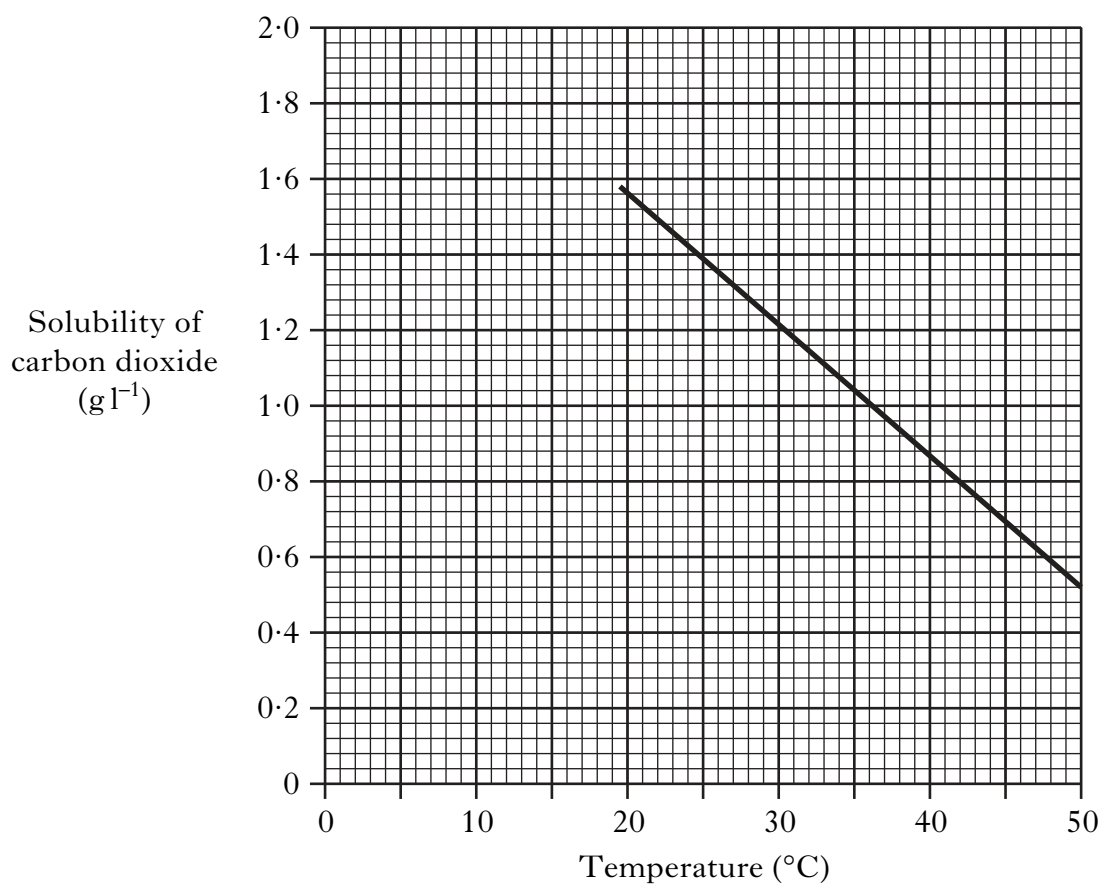

(i) Write a general statement describing the effect of temperature on the solubility of carbon dioxide gas.

---

---

1

(ii) Use the graph to predict the solubility of carbon dioxide at 10 °C.

\_\_\_\_\_ g l<sup>-1</sup>

1  
(3)

Marks

11. Slaked lime can be added to lochs to reduce acidity.

(a) What causes the lochs to become acidic?

\_\_\_\_\_

**1**

(b) Slaked lime can be made from limestone.

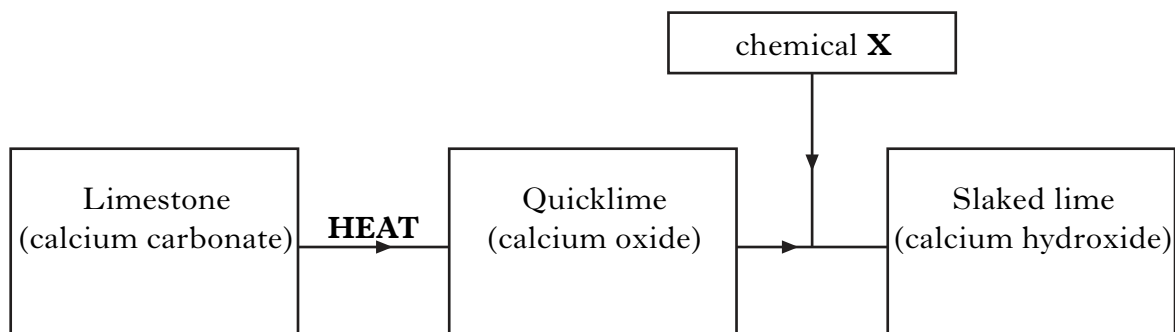

(i) Name the elements present in calcium carbonate.

\_\_\_\_\_

**1**

(ii) Suggest a name for chemical **X**.

\_\_\_\_\_

**1****(3)**

Marks

12. Lamp posts made of iron or steel can have different coatings to prevent rusting.



- (a) Some lamp posts are coated in a layer of paint.

How does the layer of paint prevent the iron lamp post from rusting?

---

---

1

- (b) Lamp posts can also be coated by dipping them in molten zinc.

- (i) What term is used to describe this process?

---

1

- (ii) Why does the iron not rust even when the zinc coating is scratched?

---

---

1

(3)

[Turn over

Marks

13. Sodium sulphate crystals can be made from sodium hydroxide solution and dilute sulphuric acid as shown in the procedure below.

Step 1

Add sodium hydroxide solution to dilute sulphuric acid until

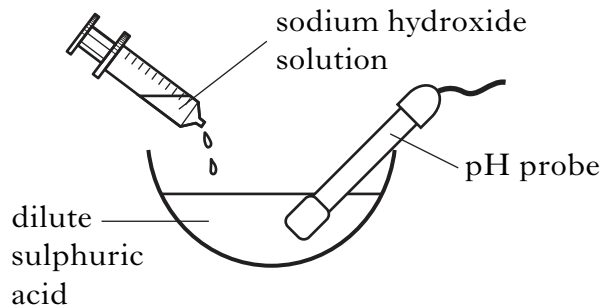

---



---



---

Step 2

Evaporate until half of the solution remains.

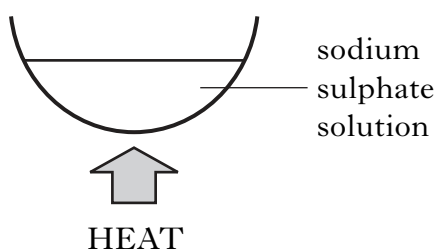

Step 3

Leave until the remaining water evaporates.

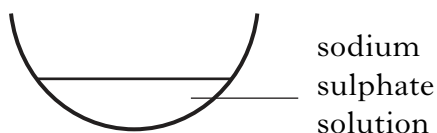

Step 4

Sodium sulphate crystals are formed.

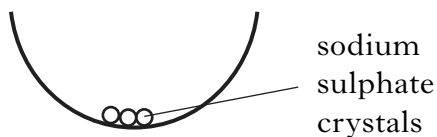

(a) Complete the instructions for Step 1.

1

Marks

**13. (continued)**

(b) The equation for the reaction is:



In the experiment  $50 \text{ cm}^3$  of sodium hydroxide solution reacted with  $20 \text{ cm}^3$   $0.1 \text{ mol l}^{-1}$  dilute sulphuric acid.

Calculate the concentration of the sodium hydroxide solution.

\_\_\_\_\_  $\text{mol l}^{-1}$       **2**  
**(3)**

**[Turn over**

Marks

14. (a) In a **PPA**, a student was asked to investigate if the type of electrolyte used affects the voltage produced in a cell.

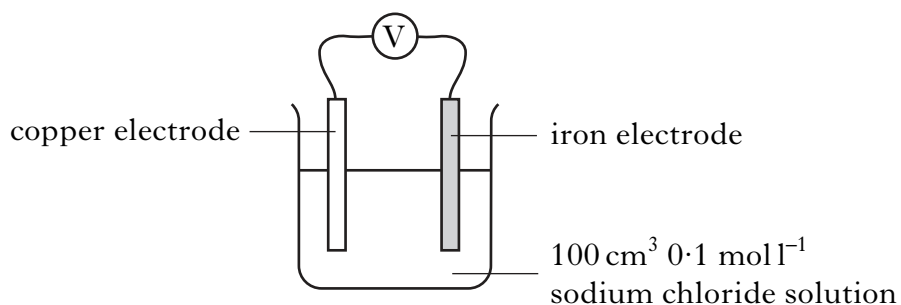

- (i) Complete the labelling of a second cell which could be used to compare the effect of changing the electrolyte from sodium chloride to hydrochloric acid.

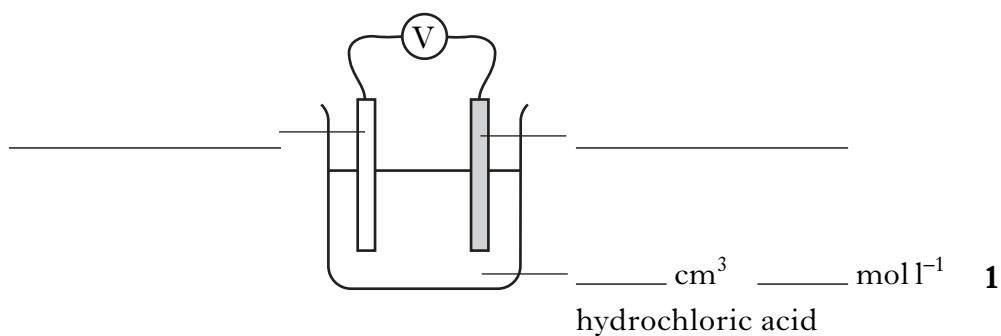

- (ii) What is done during this PPA to make sure the results are reliable?

\_\_\_\_\_ 1

Marks

**14. (continued)**

(b) Cells can also be made in which both metals and non-metals are used.

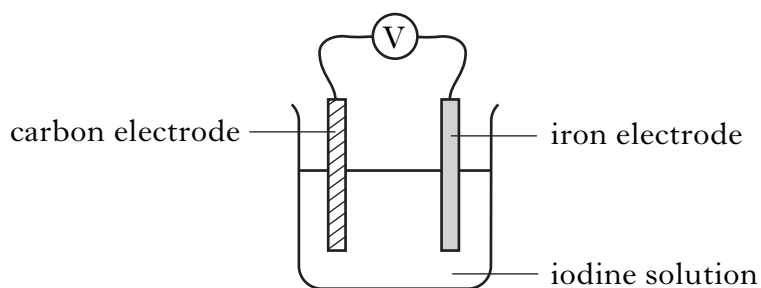

- (i) The ion-electron equation for the reaction taking place at the carbon electrode is:

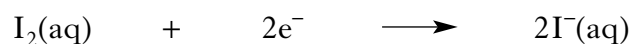

On the diagram clearly mark the path and direction of electron flow.

- (ii) What property of carbon makes it suitable for use as an electrode?

---

1

1

**(4)**

[END OF QUESTION PAPER]

**ADDITIONAL SPACE FOR ANSWERS**

--	--

**ADDITIONAL SPACE FOR ANSWERS**

--	--

**ADDITIONAL SPACE FOR ANSWERS**

--	--