

FOR OFFICIAL USE

--	--	--	--	--	--

Section B

Total  
Marks

--

**X012/201**

NATIONAL  
QUALIFICATIONS  
2011

THURSDAY, 26 MAY  
1.00 PM – 3.00 PM

CHEMISTRY  
INTERMEDIATE 2

Fill in these boxes and read what is printed below.

Full name of centre

--

Town

--

Forename(s)

--

Surname

--

Date of birth

Day    Month    Year

--	--	--	--	--	--

Scottish candidate number

--	--	--	--	--	--	--	--	--	--

Number of seat

--

Necessary data will be found in the Chemistry Data Booklet for Standard Grade and Intermediate 2.

**Section A – Questions 1–30 (30 marks)**

Instructions for completion of **Section A** are given on page two.

For this section of the examination you must use an **HB pencil**.

**Section B (50 marks)**

All questions should be attempted.

The questions may be answered in any order but all answers are to be written in the spaces provided in this answer book, **and must be written clearly and legibly in ink**.

Rough work, if any should be necessary, should be written in this book, and then scored through when the fair copy has been written. If further space is required, a supplementary sheet for rough work may be obtained from the Invigilator.

Additional space for answers will be found at the end of the book. If further space is required, supplementary sheets may be obtained from the Invigilator and should be inserted inside the **front** cover of this booklet.

Before leaving the examination room you must give this book to the Invigilator. If you do not, you may lose all the marks for this paper.



### Read carefully

- 1 Check that the answer sheet provided is for **Chemistry Intermediate 2 (Section A)**.
- 2 For this section of the examination you must use an **HB pencil** and, where necessary, an eraser.
- 3 Check that the answer sheet you have been given has **your name, date of birth, SCN** (Scottish Candidate Number) and **Centre Name** printed on it.  
Do not change any of these details.
- 4 If any of this information is wrong, tell the Invigilator immediately.
- 5 If this information is correct, **print** your name and seat number in the boxes provided.
- 6 The answer to each question is **either** A, B, C or D. Decide what your answer is, then, using your pencil, put a horizontal line in the space provided (see sample question below).
- 7 There is **only one correct** answer to each question.
- 8 Any rough working should be done on the question paper or the rough working sheet, **not** on your answer sheet.
- 9 At the end of the examination, put the **answer sheet for Section A inside the front cover of this answer book**.

### Sample Question

To show that the ink in a ball-pen consists of a mixture of dyes, the method of separation would be

- A chromatography
- B fractional distillation
- C fractional crystallisation
- D filtration.

The correct answer is **A**—chromatography. The answer **A** has been clearly marked in **pencil** with a horizontal line (see below).

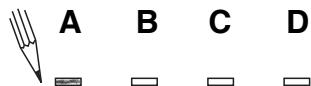

### Changing an answer

If you decide to change your answer, carefully erase your first answer and using your pencil, fill in the answer you want. The answer below has been changed to **D**.



SECTION A

1. Which of the following compounds contains both a transition metal ion and a halide ion?

- A Aluminium bromide
- B Cobalt chloride
- C Iron oxide
- D Sodium fluoride

2. Which of the following compounds contains only two elements?

- A Magnesium hydroxide
- B Magnesium phosphate
- C Magnesium sulphite
- D Magnesium nitride

3. A student investigated the reaction between marble chips and excess dilute hydrochloric acid.

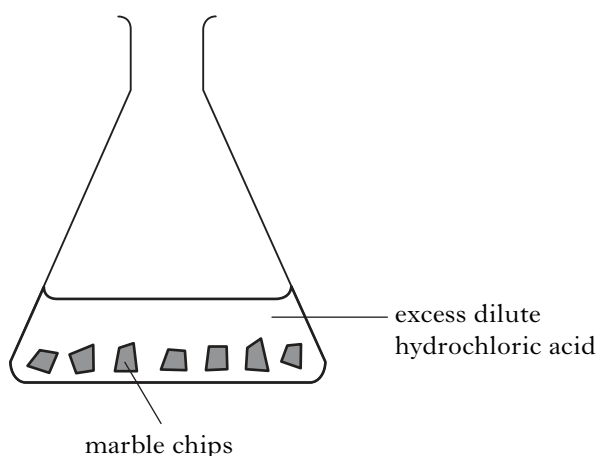

Which of the following would **not** affect the rate of the reaction?

- A Increasing the volume of the acid
- B Decreasing the size of the marble chips
- C Decreasing the concentration of the acid
- D Increasing the temperature of the acid

4. Which line in the table describes a **neutron**?

	Mass	Charge
A	1	-1
B	negligible	0
C	1	+1
D	1	0

5. An atom has 26 protons, 26 electrons and 30 neutrons. The atom has

- A atomic number 26, mass number 56
- B atomic number 56, mass number 30
- C atomic number 30, mass number 26
- D atomic number 52, mass number 56.

6. Excess magnesium is burned in an enclosed volume of air.

Which line in the table best describes the gas after burning is complete?

	Oxygen	Nitrogen	Carbon dioxide
A	1%	98%	0.03%
B	1%	79%	19%
C	16%	79%	4%
D	20%	79%	0.03%

7. Copper is a good conductor of electricity because

- A the atoms are free to vibrate
- B the atoms are in close contact
- C the atoms have the electron arrangement 2, 8, 18, 1
- D electrons can move readily from one atom to the next.

[Turn over

8. What is the charge on the chromium ion in  $\text{CrCl}_3$ ?
- A 1+  
B 1-  
C 3+  
D 3-
9. What name is given to the reaction shown by the following equation?
- $$\text{C}_6\text{H}_{12}\text{O}_6 + 6\text{O}_2 \rightarrow 6\text{CO}_2 + 6\text{H}_2\text{O}$$
- A Combustion  
B Condensation  
C Dehydration  
D Hydrolysis
10. The fractional distillation of crude oil depends on the fact that different hydrocarbons have different
- A densities  
B solubilities  
C boiling points  
D ignition temperatures.
11. Which of the following molecules would most likely be present in petrol?
- A  $\text{CH}_4$   
B  $\text{C}_3\text{H}_8$   
C  $\text{C}_8\text{H}_{18}$   
D  $\text{C}_{14}\text{H}_{30}$

12. Which of the following compounds belongs to the same homologous series as the compound with the molecular formula  $\text{C}_3\text{H}_8$ ?

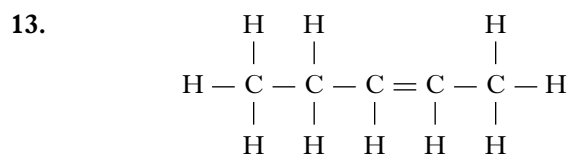
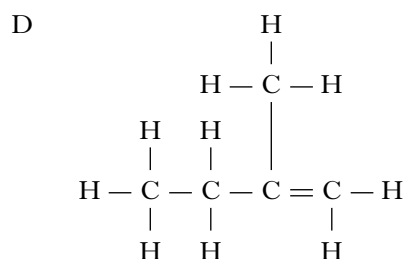
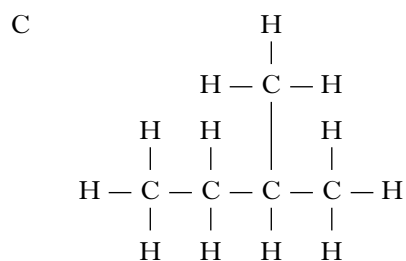
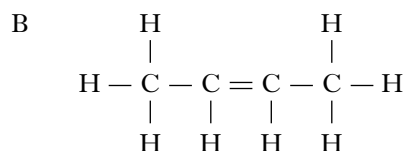
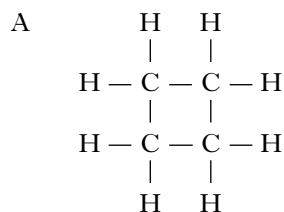

The name of the above compound is

- A but-2-ene  
B pent-2-ene  
C but-3-ene  
D pent-3-ene.

14. When propene undergoes an addition reaction with hydrogen bromide, two products are formed.

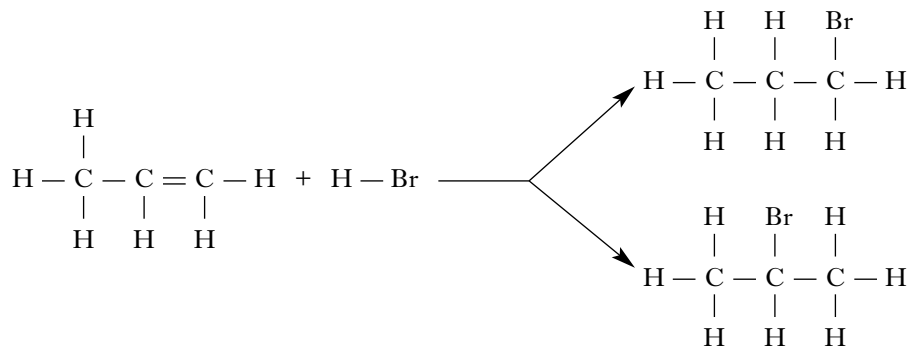

Which of the following alkenes will also produce **two** products when it undergoes an addition reaction with hydrogen bromide?

- A Ethene
- B But-1-ene
- C But-2-ene
- D Hex-3-ene

15. The table shows the result of heating two compounds with acidified potassium dichromate solution.

Compound	Acidified potassium dichromate solution
$  \begin{array}{c}  \text{H} \quad \text{H} \quad \text{O} \quad \text{H} \\    \quad   \quad    \quad   \\  \text{H}-\text{C}-\text{C}-\text{C}-\text{C}-\text{H} \\    \quad   \quad \quad   \\  \text{H} \quad \text{H} \quad \quad \text{H}  \end{array}  $	stays orange
$  \begin{array}{c}  \text{H} \quad \text{H} \quad \text{H} \quad \text{O} \\    \quad   \quad   \quad    \\  \text{H}-\text{C}-\text{C}-\text{C}-\text{C}-\text{H} \\    \quad   \quad   \\  \text{H} \quad \text{H} \quad \text{H}  \end{array}  $	turns green

Which of the following compounds will **not** turn acidified potassium dichromate solution green?

- A
 
$$\begin{array}{c}
 \text{H} \quad \text{O} \quad \text{H} \\
 | \quad || \quad | \\
 \text{H}-\text{C}-\text{C}-\text{C}-\text{H} \\
 | \quad \quad | \\
 \text{H} \quad \quad \text{H}
 \end{array}$$
- B
 
$$\begin{array}{c}
 \text{H} \quad \text{H} \quad \text{O} \\
 | \quad | \quad || \\
 \text{H}-\text{C}-\text{C}-\text{C}-\text{H} \\
 | \quad | \\
 \text{H} \quad \text{H}
 \end{array}$$
- C
 
$$\begin{array}{c}
 \text{H} \quad \text{O} \\
 | \quad || \\
 \text{H}-\text{C}-\text{C}-\text{H} \\
 | \\
 \text{H}
 \end{array}$$
- D
 
$$\begin{array}{c}
 \text{O} \\
 || \\
 \text{H}-\text{C}-\text{H}
 \end{array}$$



The above compounds are

- A isomers
- B hydrocarbons
- C alkanols
- D carbohydrates.

17. What functional group is **always** found in a protein molecule?

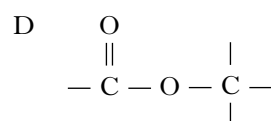
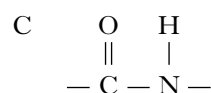
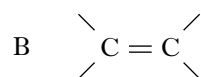
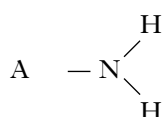

18. Which of the following are polymers?

- A Plant sugars
- B Animal fats
- C Marine oils
- D Vegetable proteins

19. Fats and oils are essential in the diet.

Which line in the table best describes an oil?

	Degree of unsaturation	Melting point
A	high	relatively high
B	high	relatively low
C	low	relatively high
D	low	relatively low

20. When one molecule of fat is completely hydrolysed, the number of ester links broken is

- A 1
- B 2
- C 3
- D 4.

21. Which of the following oxides dissolves in water to produce a solution with a pH greater than 7?

- A  $Na_2O$
- B  $Al_2O_3$
- C  $SO_2$
- D  $Ag_2O$

22. Which line in the table describes what happens to a dilute solution of hydrochloric acid when water is added to it?

	pH	$H^+(aq)$ concentration
A	increases	increases
B	increases	decreases
C	decreases	increases
D	decreases	decreases

23. Which of the following solutions has the highest pH?

- A  $0.1 \text{ mol l}^{-1}$  ammonia
- B  $0.1 \text{ mol l}^{-1}$  hydrochloric acid
- C  $0.1 \text{ mol l}^{-1}$  sodium chloride
- D  $0.1 \text{ mol l}^{-1}$  sodium hydroxide

24. Which of the following pairs of chemicals react to produce a gas that turns lime water milky?

- A Calcium carbonate and dilute hydrochloric acid
- B Copper oxide and dilute sulphuric acid
- C Copper and dilute hydrochloric acid
- D Magnesium and dilute sulphuric acid

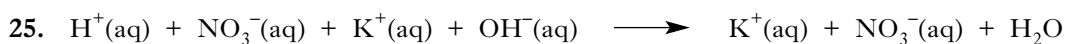

The spectator ions in the reaction are

- A  $\text{H}^+(\text{aq})$  and  $\text{K}^+(\text{aq})$
- B  $\text{NO}_3^-(\text{aq})$  and  $\text{OH}^-(\text{aq})$
- C  $\text{H}^+(\text{aq})$  and  $\text{OH}^-(\text{aq})$
- D  $\text{K}^+(\text{aq})$  and  $\text{NO}_3^-(\text{aq})$ .

26. Which of the following metals would react with zinc chloride solution?

(You may wish to use page 7 of the data booklet to help you.)

- A Copper
- B Gold
- C Iron
- D Magnesium

27.

Metal	Reaction with	
	Dilute acid	Water
<b>X</b>	reacts	no reaction
<b>Y</b>	no reaction	no reaction
<b>Z</b>	reacts	reacts

Which of the following shows the metals in order of **increasing** reactivity?

- A **X Y Z**
- B **Y X Z**
- C **Z X Y**
- D **Z Y X**

28. Some metals can be obtained from their metal oxides by heat alone.

Which of the following oxides would produce a metal when heated?

- A Calcium oxide
- B Copper oxide
- C Zinc oxide
- D Silver oxide

29. For iron to rust

- A only water must be present
- B only oxygen must be present
- C both water and oxygen must be present
- D oxygen, water and salt must be present.

30. The coatings on four strips of iron were scratched to expose the iron. The strips were placed in salt solution.

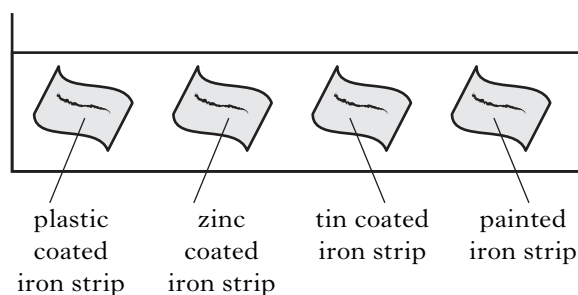

Which iron strip would have rusted most quickly?

- A Plastic coated
- B Zinc coated
- C Tin coated
- D Painted

**Candidates are reminded that the answer sheet for Section A MUST be placed INSIDE the front cover of this answer book.**

**[BLANK PAGE]**

## SECTION B

Marks

50 marks are available in this section of the paper.

All answers must be written clearly and legibly in ink.

1. The properties of a substance depend on its type of bonding and structure. There are four types of bonding and structure.

<b>Discrete covalent molecular</b>	<b>Covalent network</b>	<b>Ionic lattice</b>	<b>Metallic lattice</b>
------------------------------------	-------------------------	----------------------	-------------------------

- (a) Complete the table to match up each type of bonding and structure with its properties.

Bonding and structure type	Properties
	do not conduct electricity and have high melting points
	have high melting points and conduct electricity when liquid but not when solid
	conduct electricity when solid and have a wide range of melting points
	do not conduct electricity and have low melting points

2

- (b) A section of a covalent network compound is shown below.

● = silicon  
○ = oxygen

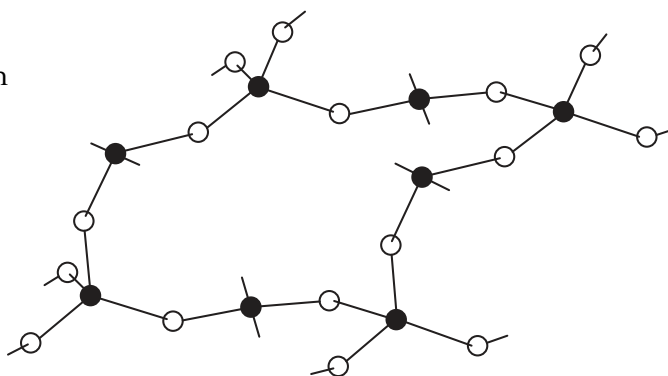

Write the formula for this covalent network compound.

\_\_\_\_\_

1  
(3)

Marks

2. Information on some two-element molecules is shown in the table.

Name	Formula	Shape of molecule
hydrogen fluoride	HF	
water	H <sub>2</sub> O	
ammonia	NH <sub>3</sub>	

(a) Complete the table to show the **shape** of a molecule of ammonia.

1

(b) The hydrogen fluoride molecule can be represented as:

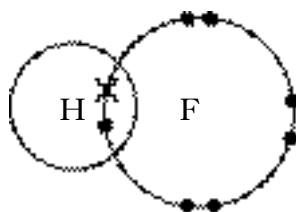

Showing **all** outer electrons, draw a similar diagram to represent a molecule of water, H<sub>2</sub>O.

1  
(2)

Marks

3. Hydrogen peroxide is a useful bleaching agent and is contained in many hair dyes. Over time, the hair dye becomes less effective as the hydrogen peroxide decomposes forming water and oxygen.

The equation for the decomposition of hydrogen peroxide is:



- (a) Balance this equation.

1

- (b) The above reaction is often used to make oxygen in the laboratory. To speed up the reaction, the catalyst manganese dioxide is added.

Complete the diagram to show how the oxygen can be collected.

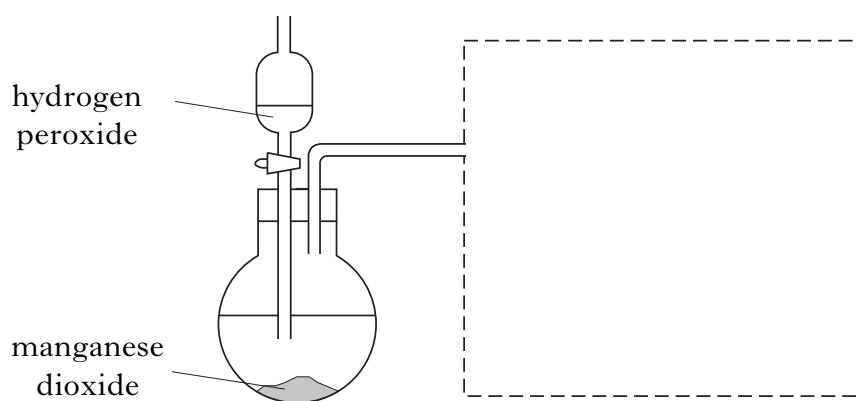

1

- (c) State the test for oxygen gas.

\_\_\_\_\_

1

- (d) When 34 g of hydrogen peroxide decomposes, 12 litres of oxygen is produced.

Calculate the volume of oxygen produced when 1.7 g of hydrogen peroxide decomposes.

\_\_\_\_\_ litres

1

(4)

Marks

4. Research is being carried out into making chemicals that can be used to help relieve the side effects of chemotherapy.

Part of the process is shown.



- (a) (i) This reaction is catalysed using the homogeneous catalyst, ruthenium(II) chloride.

What is meant by a homogeneous catalyst?

---

---

1

- (ii) Write the formula for ruthenium(II) chloride.

1

- (b) As the reaction proceeds the hydrogen is used up and the pressure decreases.

<b>Time (min)</b>	0	5	10	15	20	30	35	45
<b>Decrease in pressure (bar)</b>	0	0.6	1.2	1.7	2.2	2.9	3.1	3.1

Marks

## 4. (b) (continued)

- (i) Draw a line graph showing the decrease in pressure as time proceeds.

(Additional graph paper, if required, will be found on Page twenty-six.)

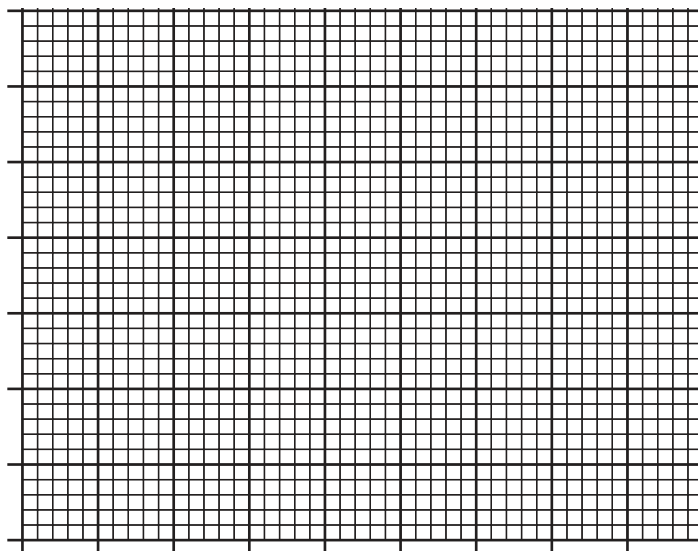

2

- (ii) Using your graph, at what time did the reaction finish?

\_\_\_\_\_ min

1

- (iii) Calculate the average rate of the reaction, in  $\text{bar min}^{-1}$ , between 10 and 20 minutes.

\_\_\_\_\_  $\text{bar min}^{-1}$

1

(6)

*Marks*

5. Ammonium sulphate is a commonly used fertiliser. It can be produced by the reaction between ammonium carbonate and calcium sulphate.



- (a) Name this type of chemical reaction.

\_\_\_\_\_

**1**

- (b) What mass of ammonium carbonate,  $(\text{NH}_4)_2\text{CO}_3$ , would be needed to make 13.2 kg of ammonium sulphate,  $(\text{NH}_4)_2\text{SO}_4$ ?

\_\_\_\_\_ kg

**2****(3)**

Marks

6. In the PPA “Hydrolysis of starch”, dilute hydrochloric acid can be used to break down starch.

A section of a student’s workcard is shown.

1. Set up the experiment as shown in the diagram.

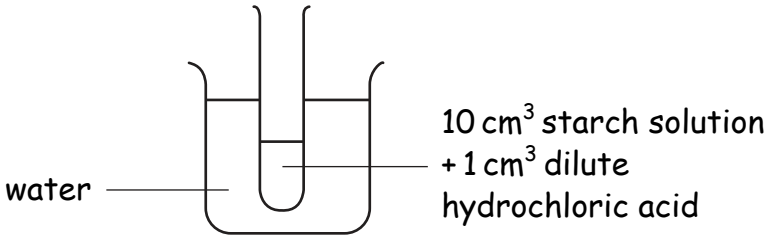

water ———

10 cm<sup>3</sup> starch solution  
+ 1 cm<sup>3</sup> dilute  
hydrochloric acid

2. Boil the water in the beaker for 5 minutes and then turn off the Bunsen burner.

3. Add a small amount of solid sodium hydrogencarbonate to the test tube.

4. Add 5 cm<sup>3</sup> of Benedict’s solution to the test tube and warm gently.

5. Observe and record your results.

- (a) After heating with dilute hydrochloric acid, solid sodium hydrogencarbonate is added to the reaction mixture.

Why is sodium hydrogencarbonate needed?

---



---

1

- (b) A control experiment is used in this PPA.

Label the diagram to show this control experiment.

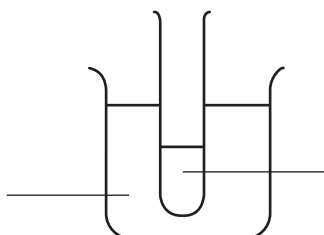

1  
(2)

Marks

7. When marking a student's report on plastics, the teacher circled three errors.

The marked report is shown.

Most plastics are made from chemicals which come from <sup>1</sup>coal.  
Plastics are made when monomers polymerise to form polymers.  
Some common plastics are polystyrene, poly(ethene) and Biopol:  
• Polystyrene is made from the monomer <sup>2</sup>propene  
• Poly(ethene) is a thermoplastic  
• <sup>3</sup>Biopol is a plastic which is soluble in water.

Correct the circled errors.

1 \_\_\_\_\_

2 \_\_\_\_\_

3 \_\_\_\_\_

(3)

Marks

8. Many different gases are found in car exhaust fumes. Some of these gases are produced by the combustion of petrol in car engines.

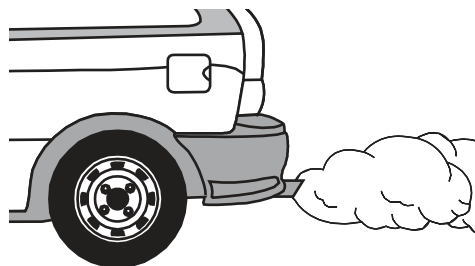

The pie chart shows the gases present in the exhaust fumes of a car.

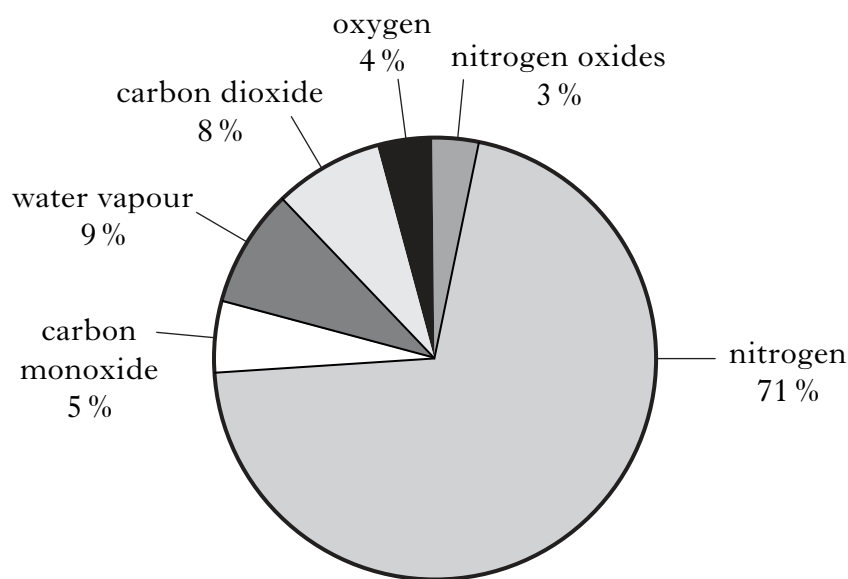

- (a) What evidence in the pie chart shows that incomplete combustion of petrol has taken place?

\_\_\_\_\_

1

- (b) The car's exhaust fumes were found to contain 3 % nitrogen oxides.  
Predict the percentage of nitrogen oxides that could be found in the exhaust fumes if the car was fitted with a catalytic convertor.

\_\_\_\_\_ %

1

- (c) The burning of some fuels releases sulphur dioxide into the atmosphere.

Why is this a problem?

\_\_\_\_\_

\_\_\_\_\_

1

(3)

Marks

9.



The little pen-tailed tree shrew, found in the jungles of West Malaysia, feeds on nectar from the Bertam palm tree. This nectar contains glucose which ferments, producing solutions of up to 3.8% alcohol. Therefore, the tree shrew regularly drinks a solution which is equivalent to a man drinking 9 units of alcohol per day. It seems that the tree shrew never gets drunk because it is able to breakdown the alcohol much quicker than humans can.

- (a) Name the process by which plants make glucose from carbon dioxide and water.

---

1

- (b) What **type** of substance must be present in the nectar to allow the fermentation of glucose to take place?

---

1

- (c) The alcohol produced is ethanol.

Draw the **shortened structural formula** for ethanol.

1

- (d) Using information in the passage above, calculate the volume of alcohol solution the tree shrew drinks each day.

$$\text{Volume of alcohol solution} = \frac{\text{units of alcohol} \times 1.25}{\% \text{ of alcohol}}$$

---

 cm<sup>3</sup>

1

(4)

Marks

10. Synthetic nappies contain hydrogel polymers which attract and absorb water molecules.

(a) The following is part of the structure of a hydrogel polymer.

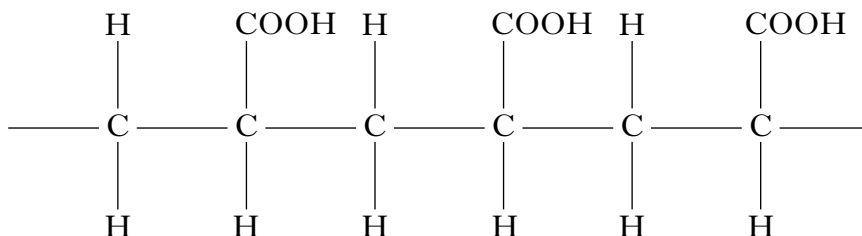

(i) Draw the monomer from which this polymer is made.

1

(ii) The diagram below shows how water molecules are attracted to the hydrogel.

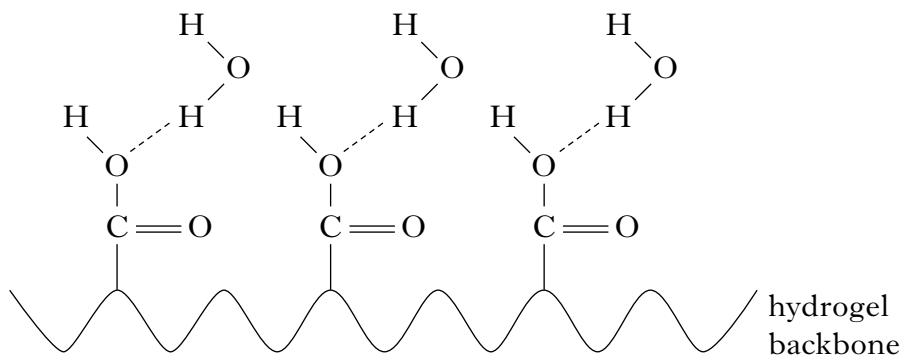

What type of bonding must be present **in the water molecules**, which allows them to be attracted to the hydrogel?

1

(b) Many hydrogels are polymers of carboxylic acids. Carboxylic acids are weak acids.

What is meant by a **weak** acid?

1

(3)

Marks

11. Many different molecules give us different smells and tastes.

(a) The following molecule gives a “fishy” smell.

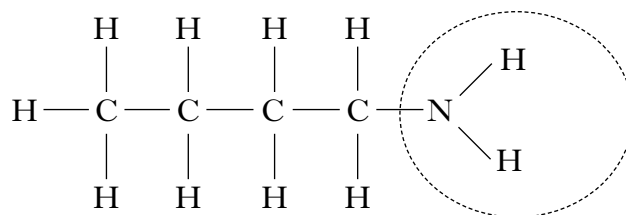

Name the functional group circled in this molecule.

1

(b) Artificial flavourings added to foods are often esters.

The following ester gives an orange flavour.

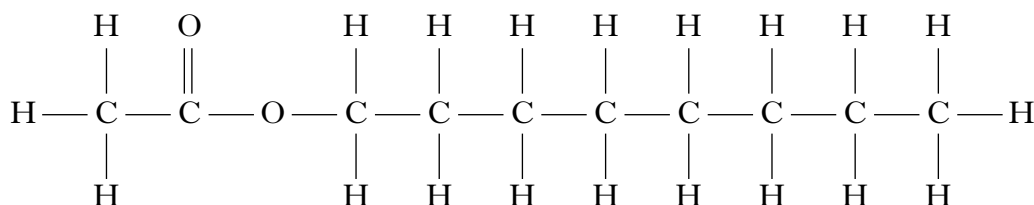

Name this ester.

1

(c) Some household cleaners contain the chemical limonene which gives them a lemon smell. The structure of limonene is shown below.

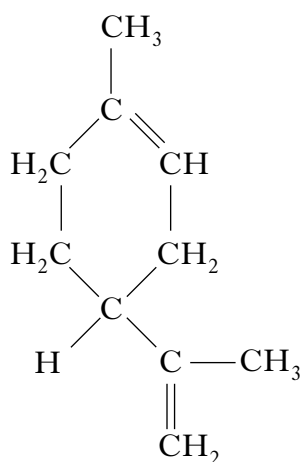

## 11. (c) (continued)

Marks

Using bromine solution, a student carried out titrations to determine the concentration of limonene in a household cleaner.

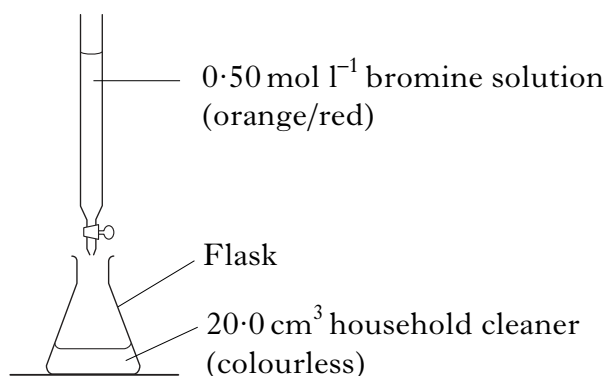

Titration	Initial burette reading (cm <sup>3</sup> )	Final burette reading (cm <sup>3</sup> )	Titre (cm <sup>3</sup> )
1	0.5	17.1	16.6
2	0.2	16.3	16.1
3	0.1	16.0	15.9

- (i) What colour change would be seen in the flask that indicates the end point of the titrations?

\_\_\_\_\_ to \_\_\_\_\_ **1**

- (ii) What average volume should be used in calculating the concentration of limonene?

\_\_\_\_\_ cm<sup>3</sup> **1**

- (iii) The equation for the reaction between limonene and bromine solution is shown.

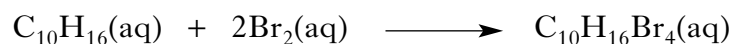

Calculate the concentration of limonene in the household cleaner.

\_\_\_\_\_ mol l<sup>-1</sup> **2**  
**(6)**

Marks

12. Metals can be extracted from metal compounds by heat alone, heating with carbon or by electrolysis.

(a) Name the type of chemical reaction which takes place when a metal is extracted from its compound.

\_\_\_\_\_

1

(b) In a **PPA**, a solution of copper(II) chloride was electrolysed.

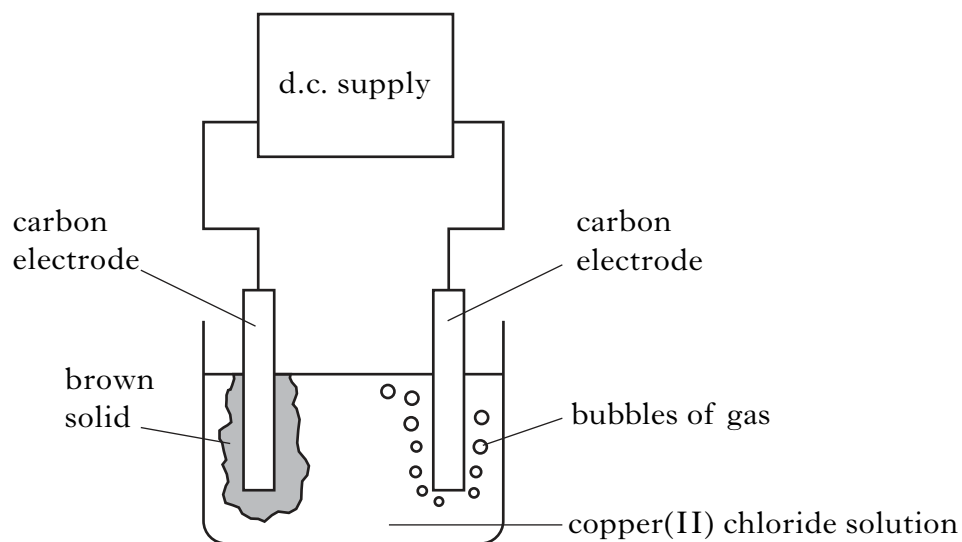

(i) Complete the table by adding the charge for each electrode.

Observation at _____ electrode	Observation at _____ electrode
bubbles of gas	brown solid formed

1

(ii) How could the gas be identified?

\_\_\_\_\_

\_\_\_\_\_

1  
(3)

Marks

13. Some indicators can have different colours when in solutions of different pH values.

The tables give information about two indicators, bromothymol blue and methyl orange.

Bromothymol blue	
Colour	pH
yellow	below 6.0
blue	above 7.6

Methyl orange	
Colour	pH
red	below 3.1
yellow	above 4.4

The pH of three solutions was investigated using both indicators.

The results are shown below.

Substance	Colour with bromothymol blue	Colour with methyl orange
A	yellow	red
B	yellow	yellow
C	blue	yellow

- (a) Which solution is alkaline?

Solution \_\_\_\_\_

1

- (b) Suggest a pH value for solution B.

pH \_\_\_\_\_

1  
(2)

[Turn over

Marks

14. The voltage obtained when different pairs of metal strips are connected in a cell varies and this leads to the electrochemical series.

Using the apparatus below, a student investigated the electrochemical series. Copper and four other metal strips were used in this investigation.

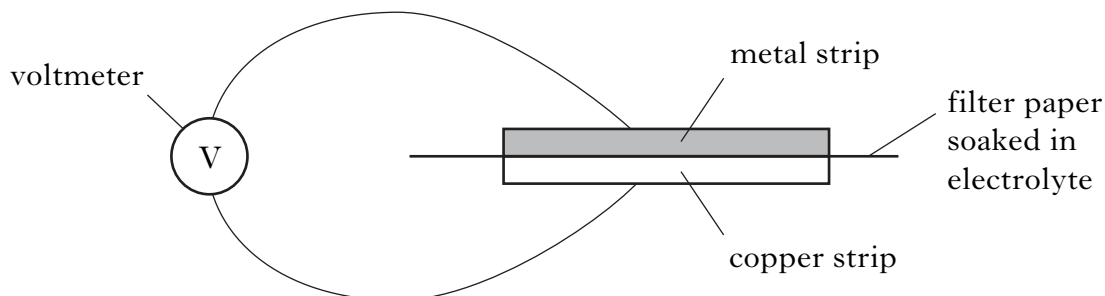

The results are shown.

Metal strip	Voltage (V)	Direction of electron flow
1	0.6	metal 1 to copper
2	0.2	copper to metal 2
3	0.9	metal 3 to copper
4	0.1	copper to metal 4

- (a) Which of the metals used is highest in the electrochemical series?  
metal \_\_\_\_\_ **1**
- (b) Which **two** of the metals used would produce the highest voltage when connected in a cell?  
metal \_\_\_\_\_ and metal \_\_\_\_\_ **1**
- (c) What would be the reading on the voltmeter if both strips of metal were copper?  
\_\_\_\_\_ V **1**
- (d) Why can glucose solution **not** be used as the electrolyte?  
\_\_\_\_\_ **1**

**(4)**

Marks

15. Fizzy drinks contain acids.

These acids can attack the compound calcium hydroxyapatite which is found in tooth enamel.

The equation for the reaction is:

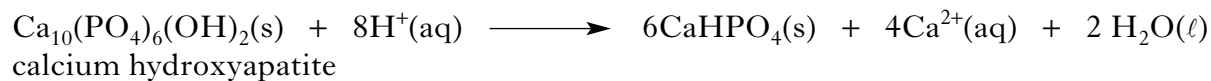

(a) What will happen to the pH as the tooth enamel is attacked by the acids?

\_\_\_\_\_

1

(b) Fluoride prevents tooth decay by replacing the hydroxide ions of calcium hydroxyapatite with fluoride ions to form hard wearing calcium fluoroapatite.

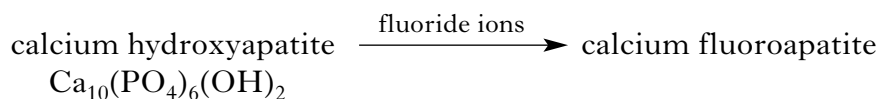

Write the formula for calcium fluoroapatite.

1

(2)

[END OF QUESTION PAPER]

**ADDITIONAL SPACE FOR ANSWERS**

ADDITIONAL GRAPH PAPER FOR QUESTION 4(b)(i)

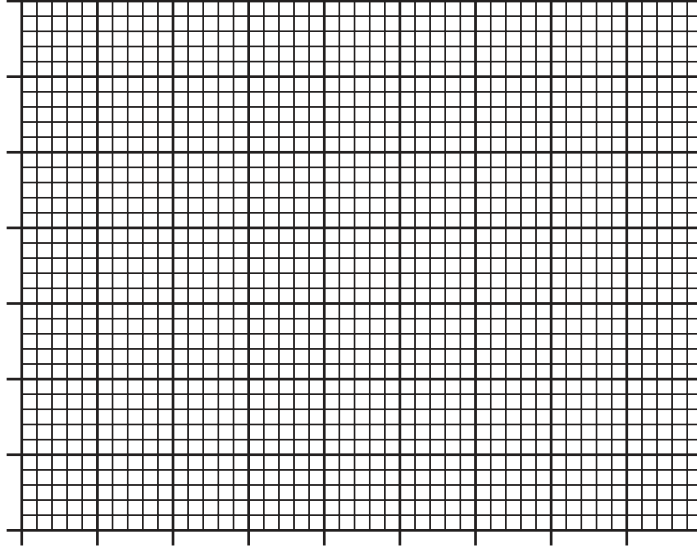

**ADDITIONAL SPACE FOR ANSWERS**

--	--

**ADDITIONAL SPACE FOR ANSWERS**

--	--