

FOR OFFICIAL USE

--	--	--	--	--	--

National  
Qualifications  
2026

Mark

--

X847/75/01

# Mathematics Paper 1 (Non-calculator)

FRIDAY, 8 MAY  
9:00 AM – 10:00 AM



Fill in these boxes and read what is printed below.

Full name of centre

--

Town

--

Forename(s)

--

Surname

--

Number of seat

--

Date of birth

Day

--	--

Month

--	--

Year

--	--

Scottish candidate number

--	--	--	--	--	--	--	--	--	--

Total marks — 40

Attempt ALL questions.

You must NOT use a calculator.

To earn full marks you must show your working in your answers.

State the units for your answer where appropriate.

Write your answers clearly in the spaces provided in this booklet. Additional space for answers is provided at the end of this booklet. If you use this space you must clearly identify the question number you are attempting.

Use blue or black ink.

Do not remove any exam materials. You must leave this booklet on your desk; if you do not, you could lose all the marks for this paper.



## FORMULAE LIST

The roots of  $ax^2 + bx + c = 0$  are  $x = \frac{-b \pm \sqrt{(b^2 - 4ac)}}{2a}$

Sine rule  $\frac{a}{\sin A} = \frac{b}{\sin B} = \frac{c}{\sin C}$

Cosine rule  $a^2 = b^2 + c^2 - 2bc \cos A$  or  $\cos A = \frac{b^2 + c^2 - a^2}{2bc}$

Area of a triangle  $A = \frac{1}{2}ab \sin C$

Volume of a sphere  $V = \frac{4}{3}\pi r^3$

Volume of a cone  $V = \frac{1}{3}\pi r^2 h$

Volume of a pyramid  $V = \frac{1}{3}Ah$

Standard deviation  $s = \sqrt{\frac{\Sigma(x - \bar{x})^2}{n - 1}}$

or  $s = \sqrt{\frac{\Sigma x^2 - \frac{(\Sigma x)^2}{n}}{n - 1}}$ , where  $n$  is the sample size.



\* X 8 4 7 7 5 0 1 0 2 \*

Total marks — 40  
 Attempt ALL questions

1. Expand and simplify  $(y+4)(y^2-3y+2)$ .

3

2. An electric car shows that it has enough charge remaining in its battery to travel 180 miles.

The battery has 60% of its charge remaining.

Calculate the number of miles the car can travel when the battery is fully charged.

3

[Turn over



3. A restaurant recorded the waiting times to be seated from a sample of its customers.

The waiting times, in minutes, of ten customers were:

2 20 5 14 2 4 8 18 6 15

(a) Calculate the median and interquartile range of the waiting times.

3

A café also recorded the waiting times to be seated from a sample of its customers. The median waiting time at the café was 5 minutes and the interquartile range was 12 minutes.

(b) Make two valid comments comparing the waiting times at the restaurant and at the café.

2



4. Solve, algebraically, the inequation

$$x + 8 < 3(x - 2) + 20.$$

3

5. Sam walked  $2\frac{3}{4}$  miles to a park and then walked a further  $1\frac{2}{3}$  miles to a shop.  
Calculate the total distance Sam walked.

2

[Turn over



\* X 8 4 7 7 5 0 1 0 5 \*

6. A teacher records the marks scored by the pupils in her class for the prelim exam and the final exam.

The scattergraph shows the relationship between the marks scored in the prelim exam,  $P$ , and the final exam,  $F$ .

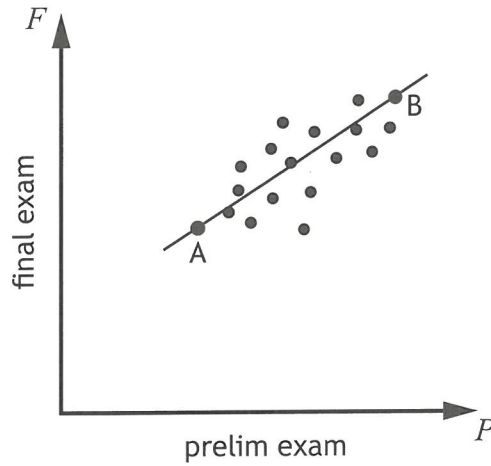

A line of best fit is drawn.

Point A represents a pupil who scored 30 in the prelim exam and 54 in the final exam.

Point B represents a pupil who scored 90 in the prelim exam and 94 in the final exam.

- (a) Find the equation of the line of best fit in terms of  $F$  and  $P$ .  
Give the equation in its simplest form.

3



6. (continued)

A pupil scored 33 marks in the prelim exam.

(b) Use your equation from part (a) to estimate their mark in the final exam.

1

7. Find  $|\mathbf{d}|$ , the magnitude of vector  $\mathbf{d} = \begin{pmatrix} 4 \\ -5 \\ 7 \end{pmatrix}$ .

Express your answer as a surd in its simplest form.

3

[Turn over



\* X 8 4 7 7 5 0 1 0 7 \*

8. Change the subject of the following formula to  $T$ .

$$P = \sqrt{T - 3L}$$

2

9. The diagram shows part of the graph of  $y = kx^2$ .

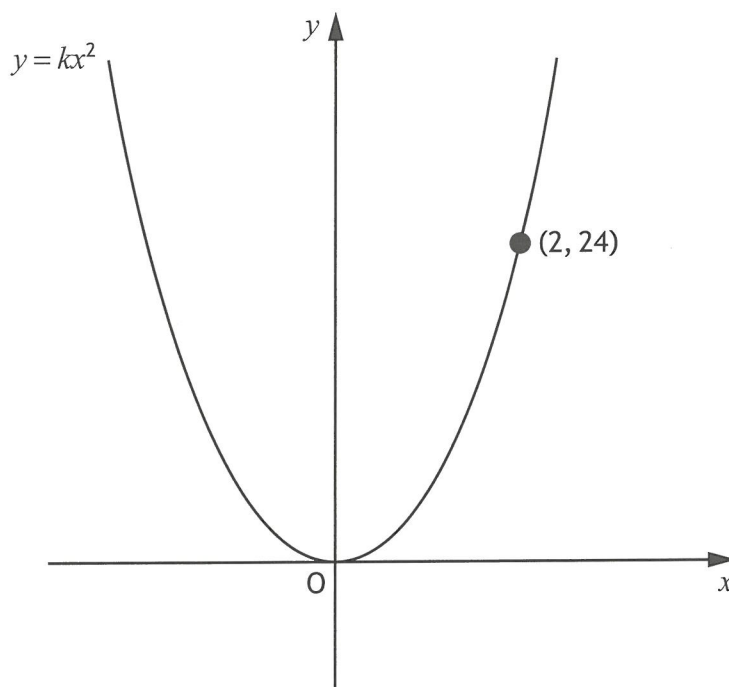

Find the value of  $k$ .

2



10. The diagram shows a circle with centre O.

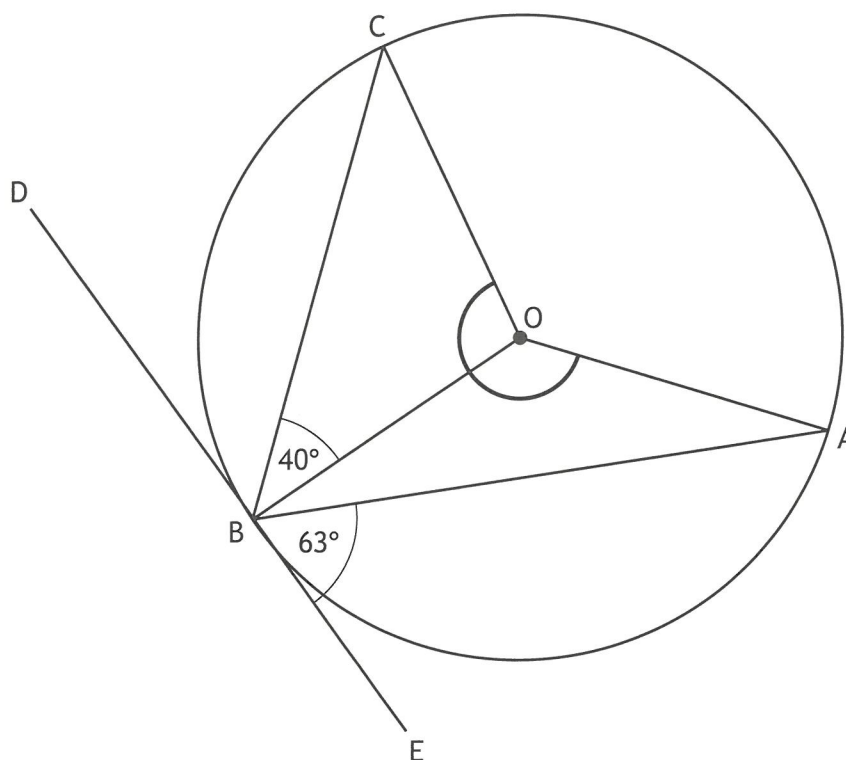

- DE is a tangent to the circle at the point B.
- Angle OBC is  $40^\circ$ .
- Angle ABE is  $63^\circ$ .

Calculate the size of the reflex angle AOC.

State your final answer below.

Reflex angle AOC =

3

[Turn over



\* X 8 4 7 7 5 0 1 0 9 \*

11. The diagram shows a cuboid, ABCDEFGH, relative to the coordinate axes.

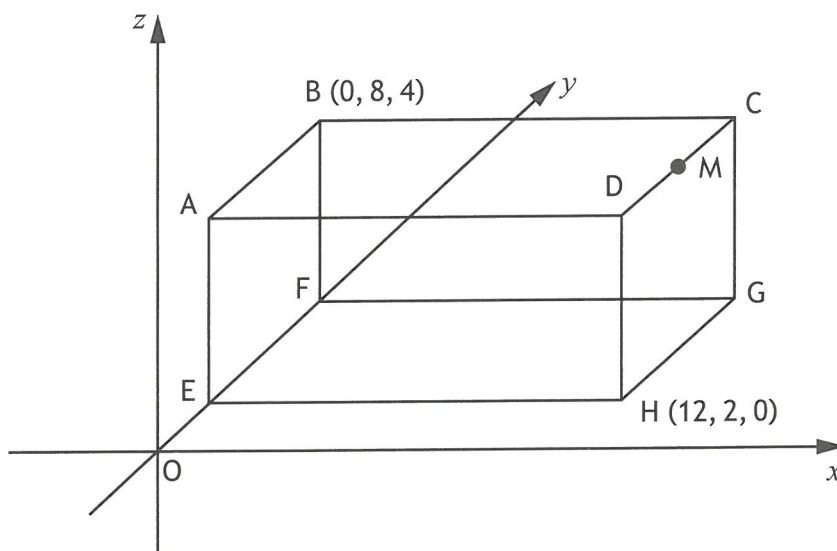

- B has coordinates (0, 8, 4).
- H has coordinates (12, 2, 0).
- EH is parallel to the  $x$ -axis.

(a) State the coordinates of G.

1

(b) M is the midpoint of CD.  
State the coordinates of M.

1



12. On the axes below, sketch the graph of  $y = (x + 2)^2 + 3$ .  
 On your sketch, show clearly the coordinates of the turning point and the point of intersection with the  $y$ -axis.  
 (Additional axes, if required, can be found on *page 13*.)

3

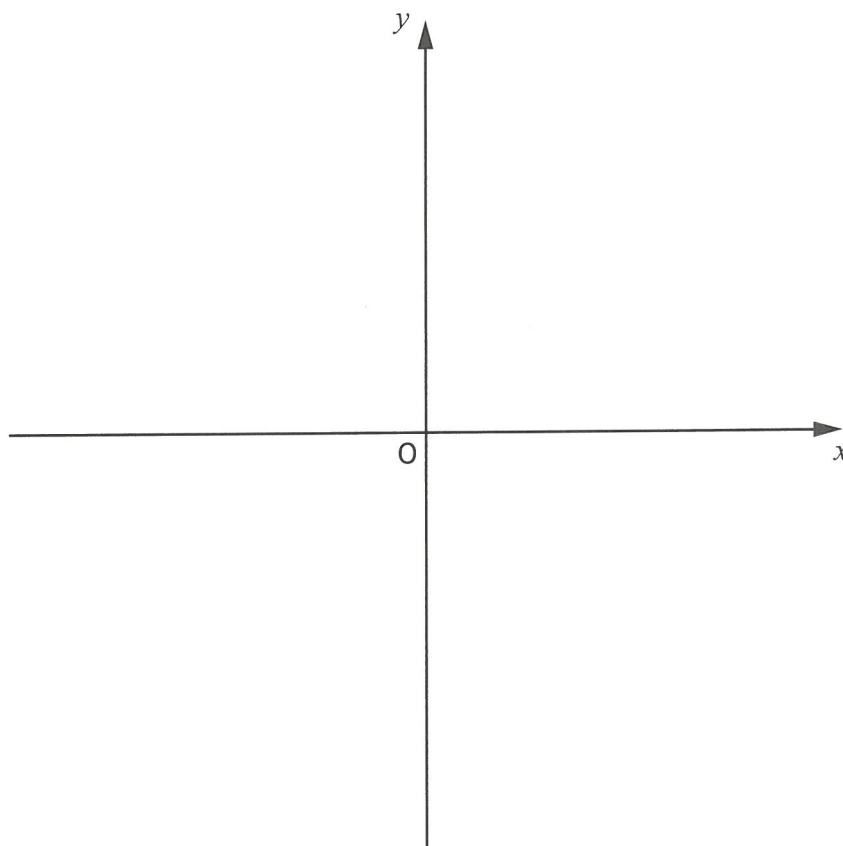

13. Given that  $f(x) = 5 \cos 2x^\circ$ , evaluate  $f(90)$ .

2

14. Solve the equation by factorising

$$10x^2 + 11x - 6 = 0.$$

3

[END OF QUESTION PAPER]





FOR OFFICIAL USE

--	--	--	--	--	--

National  
Qualifications  
2026

Mark

--

**X847/75/02**

**Mathematics  
Paper 2**

FRIDAY, 8 MAY

10:30 AM – 12:00 NOON



\* X 8 4 7 7 5 0 2 \*

Fill in these boxes and read what is printed below.

Full name of centre

--

Town

--

Forename(s)

--

Surname

--

Number of seat

--

Date of birth

Day

--	--

Month

--	--

Year

--	--

Scottish candidate number

--	--	--	--	--	--	--	--	--	--

**Total marks — 50**

Attempt ALL questions.

**You may use a calculator.**

To earn full marks you must show your working in your answers.

State the units for your answer where appropriate.

Write your answers clearly in the spaces provided in this booklet. Additional space for answers is provided at the end of this booklet. If you use this space you must clearly identify the question number you are attempting.

Use **blue** or **black** ink.

Do not remove any exam materials. You must leave this booklet on your desk; if you do not, you could lose all the marks for this paper.



\* X 8 4 7 7 5 0 2 0 1 \*

**Qualifications  
Scotland**  
Teisteanasan Alba

Total marks — 50  
Attempt ALL questions

1. A van was valued at £22,600.  
Its value depreciated by 28% each year for the next three years.  
Calculate the value of the van after three years.  
Give your answer correct to 3 significant figures.

4

[Turn over



2. In triangle XYZ:

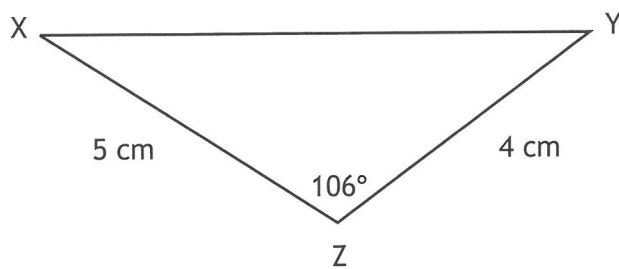

- $XZ = 5$  centimetres
- $YZ = 4$  centimetres
- angle  $XZY = 106^\circ$ .

Calculate the length of XY.

3

3. Harriet's Hand Cream is available in two sizes of bottles which are mathematically similar.

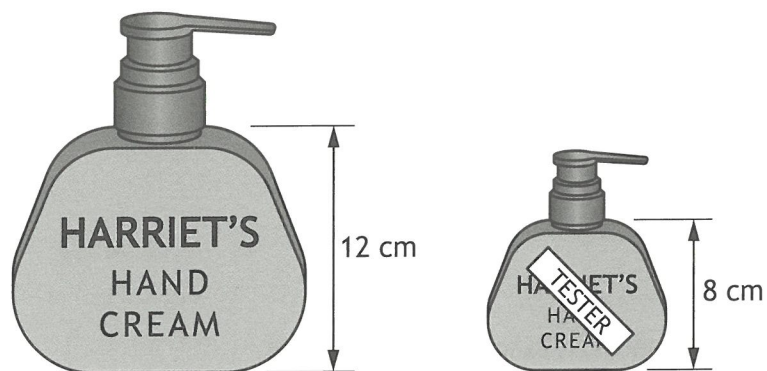

The larger bottle has a height of 12 centimetres and a volume of 540 millilitres.  
 The tester bottle has a height of 8 centimetres.  
 Calculate the volume of the tester bottle.

3

[Turn over



4. For a hobby, Alex makes cups and plates.

To make 5 cups and 6 plates, it takes Alex 45 minutes.

Let  $c$  be the number of minutes Alex takes to make a cup and  $p$  be the number of minutes Alex takes to make a plate.

(a) Write down an equation in  $c$  and  $p$  to illustrate this information.

1

To make 7 cups and 4 plates, it takes Alex 52 minutes.

(b) Write down an equation in  $c$  and  $p$  to illustrate this information.

1

(c) Calculate, algebraically, the **total** number of minutes it will take Alex to make 10 cups and 8 plates.

4



5. The diagram shows a circle, centre O, with chord AC.

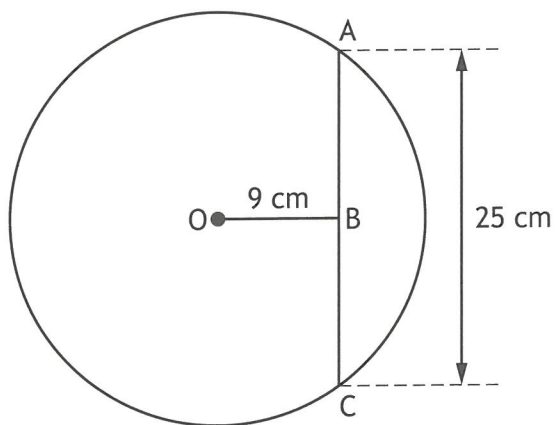

- AC is 25 centimetres.
- B is the midpoint of AC.
- OB is 9 centimetres.

Calculate the length of the radius of the circle.

3

[Turn over



6. A sphere has radius 5 centimetres.

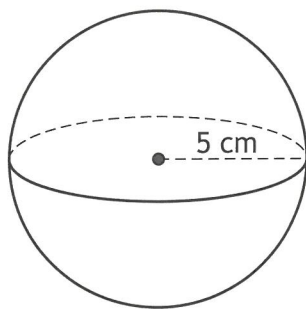

(a) Calculate the volume of the sphere.

2

6. (continued)

This cone has the same volume as the sphere.

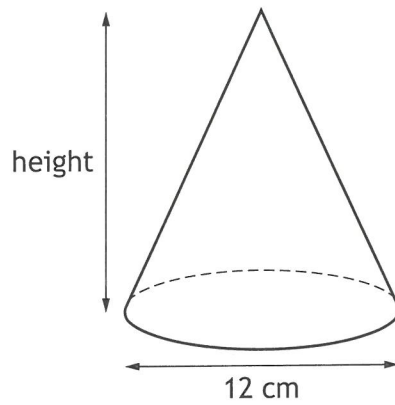

The base of the cone has diameter 12 centimetres.

(b) Calculate the height of the cone.

3

[Turn over



7. A triangle has sides of length 88 metres, 105 metres and 137 metres.

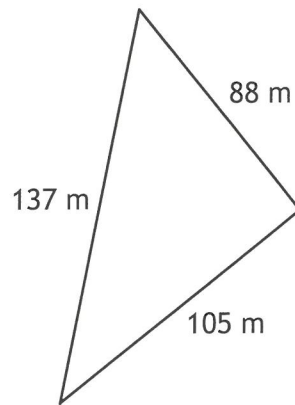

Determine whether the triangle is right-angled.  
Justify your answer.

3

8. Solve the equation

$$5 \tan x^\circ + 3 = 4, \text{ for } 0 \leq x < 360.$$

3

9. Express

$$\frac{x^2 - 81}{5} \div \frac{x + 9}{2}, \quad x \neq -9$$

as a single fraction in its simplest form.

3

[Turn over



10. The vertices of a regular pentagon, ABCDE, lie on a circle, centre O.

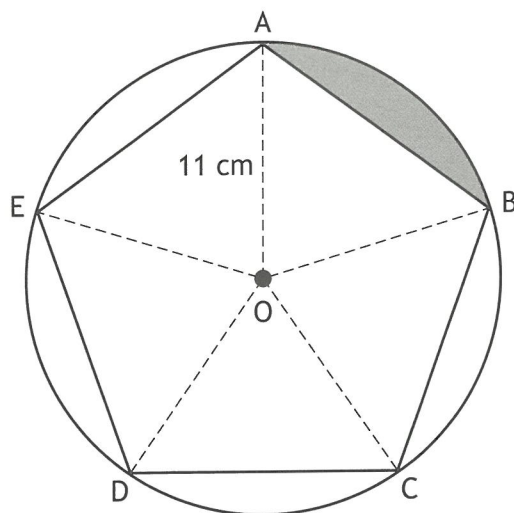

The radius of the circle is 11 centimetres.  
Calculate the area of the shaded segment.

5



3

11. Simplify  $\frac{a^{17}}{(3a^4)^3}$ .

12. Express the following in its simplest form:

$$\cos x^\circ \sin^2 x^\circ + \cos^3 x^\circ.$$

Show your working.

2

[Turn over



13. An extension with a rectangular base is being added to the rear of a house.

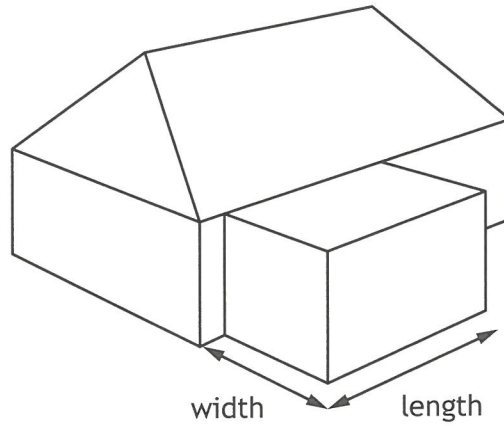

The diagram below shows a plan of the rectangular base of the extension.

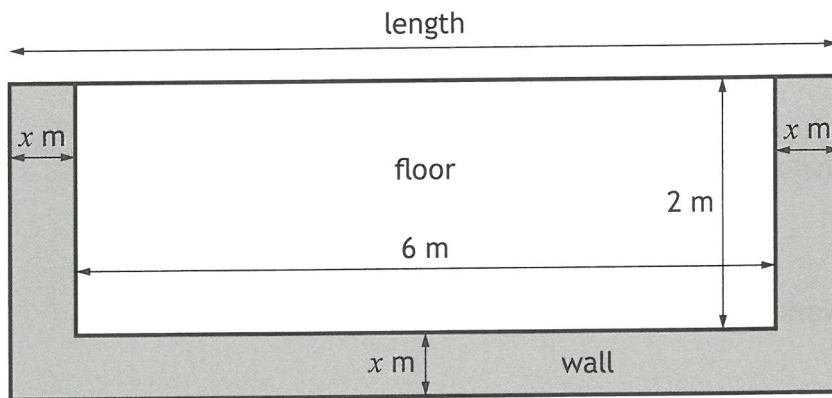

The length of the floor is 6 metres and the width of the floor is 2 metres. There is a wall  $x$  metres thick on three sides of the extension.

(a) Write down an expression for the length of the extension in terms of  $x$ .

1



13. (continued)

The total area of the rectangular base of the extension is 17 square metres.

(b) Show that  $2x^2 + 10x - 5 = 0$ .

2

(c) Calculate  $x$ , the thickness of the wall.

Give your answer correct to two decimal places.

4

[END OF QUESTION PAPER

